

# Table of Contents

Mission Statement	4
Constitution and Bylaws	5
Advisor, Coach Expectations	17
Code of Conduct	19
OHSET Rules	23
Contact and Rule Book Information	25
Rule Interpretation	26
Rule Reference , Updates	
Participation	27
Athlete Participation, eligibility	29
Uniform	31
Alternate Participation	34
Season and Scheduling	36
Patterns, Scoring	37
Judges	38
Qualifications	39
Apprentice Guidelines	39
Conduct	42
Cooperative Sponsorship	43
Team & District Co-Op	44
Scoring and Placing	47
Team, Individual Points	49
Year End District Points	50
Awards	52
Timed Event Records	53
Event Rules	56
Cattle Events	56
Breakaway Roping	58
Steer Daubing	60
Team Penning	62
Drill Team	69
Flag Protocol	71
Short Program	74
Working Fours	74
Maneuvers	74
Judging Guidelines	77
Driving	82
Dressage	84

Hunt Seat Equitation/Trail	86
Hunt Seat Over Fences	86
Saddle Seat Equitation/Trail	89
Showmanship	91
In Hand Obstacle Relay	92
Working Pairs	94
Timed Events	97
Keyhole Race	99
Pole Bending	100
Figure 8 Stake Race	101
Texas Barrels	101
Flag Race	102
Two Man Birangle	
Canadian Flag Race	
Western Classes	103
Stock Seat Equitation/Trail	103
Working Rancher	103
Reining	104
State Meet	106
Communications	108
Appendix	111
Equine Inherent Risk Law	111
2008-09 State Board of Directors	115
2008-09 Committee Chairs	116
2008-09 District Chairs	117
Score Sheets and Patterns	119
Alphabetical Order	
Dressage	
Driving	
Hunt Seat Equitation	
Hunt Seat Over Fences	
Hunt Seat Over Fences Equipment List	
In Hand Trail	
In Hand Obstacle Relay	
Reining	
Saddle Seat Equitation	
Showmanship	
Stock Seat Equitation	
Trail	
Working Pairs	
Working Rancher	

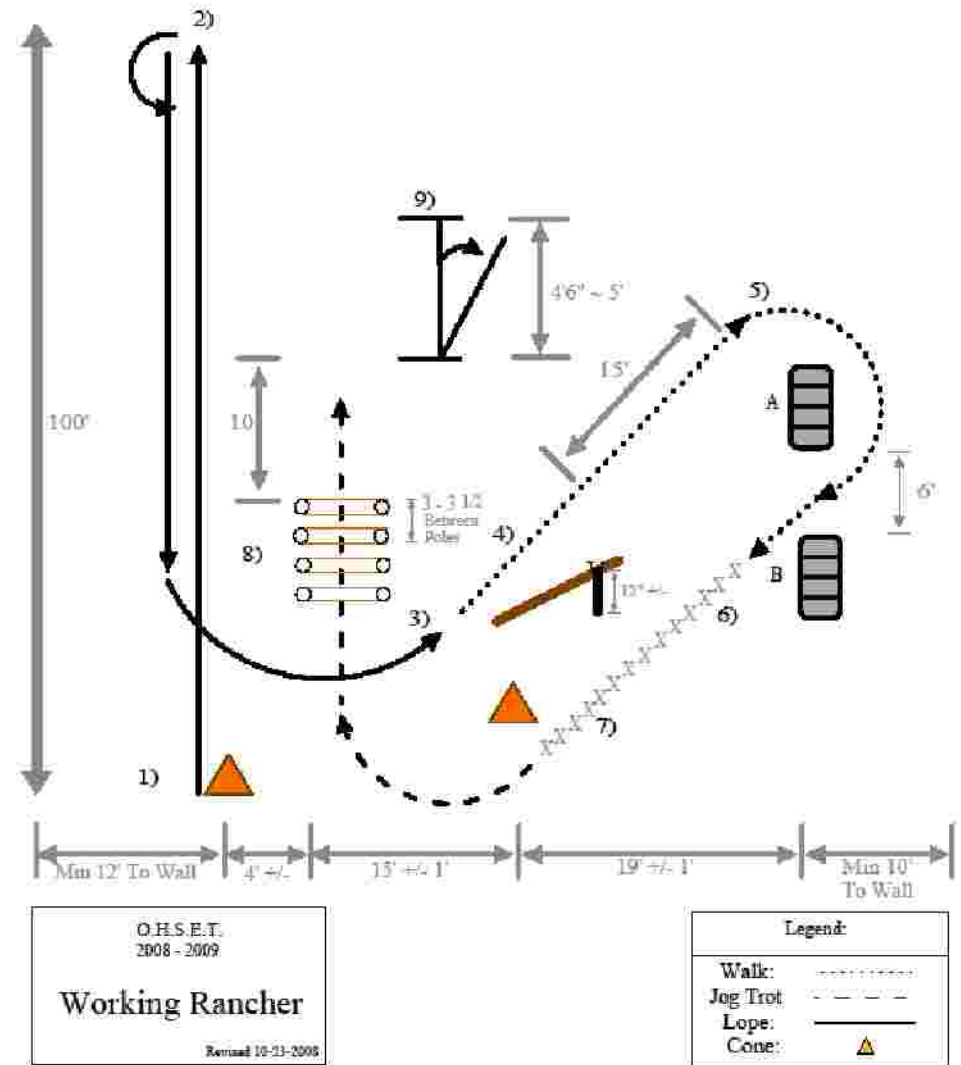

Date: \_\_\_\_\_ District: \_\_\_\_\_

**CLASS: WORKING RANCHER**

HIGH SCHOOL: \_\_\_\_\_ ATHLETE #: \_\_\_\_\_

**Expectations:**  
 The working rancher should have the ability to keep the equine moving forward at a smooth even tempo. There should be time for the equine to negotiate each obstacle just as on the ranch, but there should be no refusals or hesitation when asked to perform any task.

This pattern should be ridden with more speed and purpose than Trail or Stockseat, the athlete should have a willing and relaxed equine at all times.

A minimum of two swings are expected before throwing at the log. Exhibitors will have only one opportunity to catch; however catch is only a part of what will be judged in this element. Equally or more important are positioning, rope handling, safety and technique.

Recoil should be smooth and efficient.

**Equipment Needed:** 2 Cones, rope gate (54"-60" wide), 4, 5-7" poles/posts (6-8" diameter), 2 barrels, 1, 8" log (7"-10" in diameter) and 12" riser. Additionally, a person must be present after the drag to immediately remove rope at the cone for recoil.

#	ELEMENT JUDGED:	COMMENTS:	SCORE
1.	Enter with loop built, Pick up right lead rope		
2.	Roll back left and into left lead		
3.	Stop.		
4.	Position and rope log, jerk slack, and dally		
5.	Drag log around barrel		
6.	Turn and back, still dragging log, to cone		
7.	Re-coil		
8.	Log over poles		
9.	Dismount off side, open gate go through and close		
10.	Overall Horsemanship		

Judge's Signature: \_\_\_\_\_

Revised 12.08.08

# The Horse Blanket

*Saddles and Tack  
 Western and English  
 Carts and Harnesses*

Complete line of saddles, Billy Cook, Dale Chavez, Martin Saddlery, Circle Y, Crates, Big Horn, Colorado, New and Used.  
 Wash and repair blankets and saddle pads.  
 Repair on leather goods.  
 Grooming supplies. Won and Equi-gel pads.  
 Full line of western tack, bits & Myler bits  
 Silver headstalls, halters, bits and spurs  
 Ask about our O.H.S.E.T. Discount.  
 We have outfitted many of Oregon's finest drill teams, call us to see how we can help your team.

**DIRECTIONS TO THE HORSE BLANKET**  
From I-5 exit 33  
 South bound turn right, North bound turn left, drive 8 blocks on Pine street.  
 Look for the horse on the roof on the left side.  
 420 E Pine St., Central Point 541-664-4644  
[www.thehorseblanket.com](http://www.thehorseblanket.com)

## MISSION STATEMENT

Oregon High School Equestrian Teams (OHSET) shall be a “not for profit” corporation dedicated to promoting and organizing equestrian competition in high school athletic or activity programs.

Oregon High School Equestrian Teams (OHSET) has as its main goal, recognition in the high schools of the equestrian athlete and to give them an opportunity to achieve that recognition in a fair, positive and educational format. The goals are to encourage team play, peer acceptance and go horsemanship. Competition is to follow sportsmanship guidelines as set down by State School Activities Association and State School Board, individual participating school activity guidelines and equine sportsmanship guidelines.

Any High School in the United States of America is eligible to form a team and join the OHSET organization. The state is divided into districts. District competitions will be held with the goal of qualifying for a final State Championship Meet to be held by the host district for that current year. Each high school will have an adult and youth representation on their district board of directors. Each district will have adult and youth representatives on the State Board of Directors.

Competition is a winter/spring sport scheduled as much as possible not to conflict with other organized high school sports. The purpose is to promote continuous growth in programs fostering horsemanship education, sponsor activities to encourage interscholastic participation and to have cooperative adult supervised leadership for all students in grades 9 through 12.

High School Equestrian Teams support, challenge, and offer recognition to the dedicated teens that both physically and mentally, pursue the challenge of the sport of equine competition.

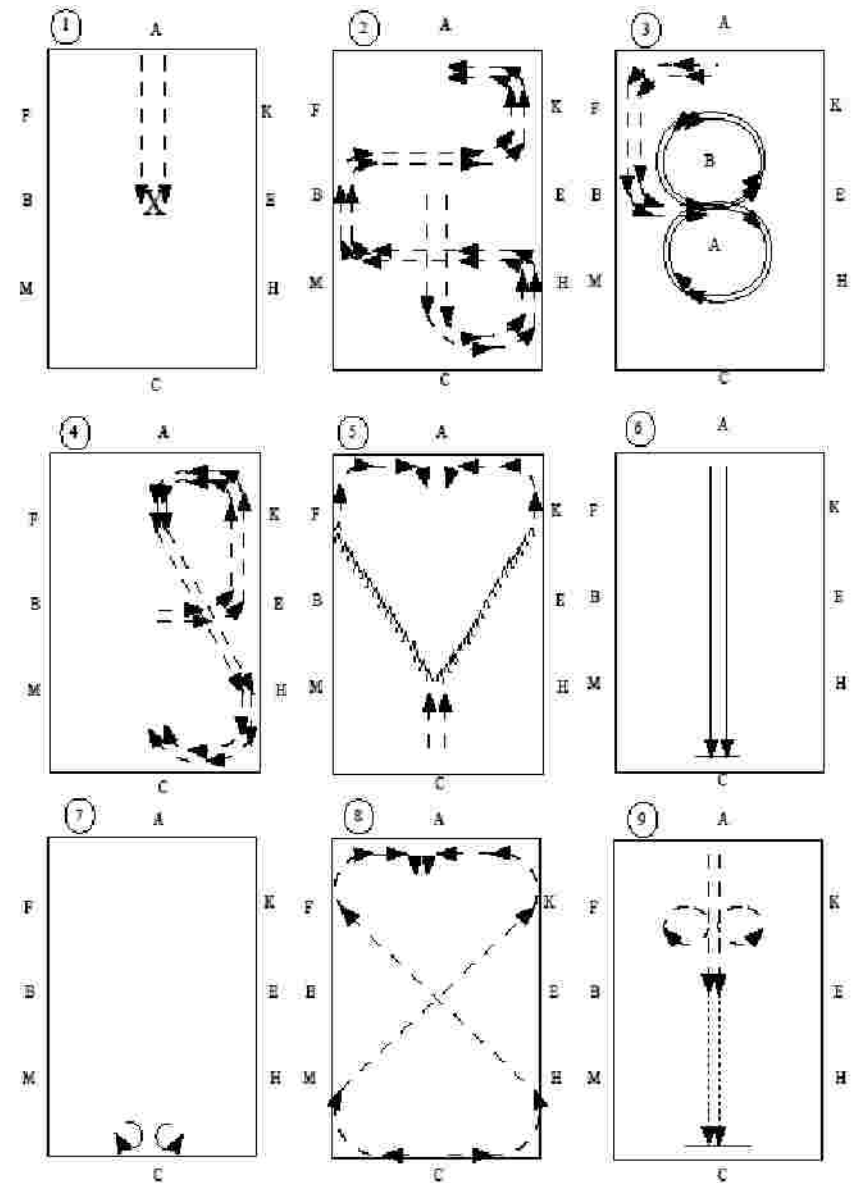

Legend:	
Walk:	.....
Jog / Trot:	.....
Extended Trot:	.....
Lope/Canter:	.....

## CONSTITUTION AND BY-LAWS OREGON HIGH SCHOOL EQUESTRIAN TEAMS, INC.

(An Oregon Non-Profit Organization)

Date: _____ District: _____			
<b>CLASS: WORKING PAIRS</b>			
HIGH SCHOOL: _____	ATHLETE #: _____		
<p>This class is judged on individual horsemanship skills, which include correct leads, balanced gaits, transitions and overall uniformity. Smooth and quiet use of aids to maintain conformity is essential.</p> <p>Mirror images are important. (Circles should be round and equal).</p> <p>Work for simultaneous fore/canter departs and haunch turns.</p> <p>Keep equines straight during leg yield.</p> <p>Timing is an essential part of this class. Use of the arena and timing of transitions will be evaluated for score.</p> <p>The pattern should be smooth overall and the music and decoration on the equines should enhance the performance and can be evaluated in the overall score.</p> <p>The close, salute and turn should also be in unison.</p>			
<p><b>Equipment Needs:</b> All Small Dressage arena letters (A, K, L, H, C, M, B, F)</p>			
#	ELEMENT JUDGED	COMMENTS:	SCORE
1	Enter as pairs at A, Jog/sitting trot, Halt, Salute at X		
2	Proceed at a jog/trot serpentine in pairs		
3	At X (center) pick up fore/canter right lead; Figure 8. At X, left lead, optional change		
4	Jog/Trot out of center to rail, turn left, continue on rail at A, trot to D (between J & K), ride short diagonal left to H, jog/trot H to C		
5	At C, trot/jog to G (between M & H), separate, and leg yield to F/K, continue trot/jog to A		
6	Come together at A, trot to center & pick up fore/canter down center to C and do a balanced stop		
7	90 degree haunch turns away from each other		
8	Pick up trot/jog at C, continue on rail through M/H, crossing at X to F/K, come together at A		
9	Turn to center, pick up trot, separate between D or X and the small angles, drop to walk, balanced stop at C, salute.		
10	Overall Horsemanship		
Judge's Signature: _____			

Revised 11-5-08

### PREAMBLE

This Constitution is established to facilitate interscholastic competition, promote a sound program of educational enrichment value and encourage a cooperative, democratic process of fair and good horsemanship with a youth focus.

### ARTICLE I - NAME

The name of this organization will be the Oregon High School Equestrian Teams, Inc. (OHSET).

### ARTICLE II - PURPOSE

The purpose of this organization, as a public benefit corporation, is to promote continuous growth in programs fostering horsemanship education, sponsor activities to encourage interscholastic participation and to have cooperative adult supervised leadership for all students in grades 9 through 12 who desire to participate regardless of race, creed or national origin and meet the association rules, constitution and bylaws. *This organization is organized exclusively for educational purposes within the meaning of section 501 (C) (3) of the Internal Revenue Code.*

### ARTICLE III - GOALS

- A. Through association leadership and coaching, it is our goal that the student members derive whatever enjoyment and benefits possible as a result of participating in horsemanship education programs and interscholastic competition.
- B. OHSET and coaches/advisors will provide situations where each equestrian team member can be exposed to cooperative working experiences that lead to common group goals.
- C. OHSET and coaches/advisors will encourage each equestrian team member by providing opportunities to experience good leadership, fair play, horsemanship, honesty, character, pride and good sportsmanship at all times.
- D. OHSET and coaches/advisors will always provide, conduct and host equestrian interscholastic programs with proper instruction, coaching methods, and conditioning rules in order to insure the health, safety and welfare of each participant and equine.
- E. OHSET will maintain the fundamental principles of the equestrian program including:

1. Eligibility for participation is determined utilizing the state's athletic association guidelines, as well as the schools criteria to participate in athletic sports.
2. Qualification for moving on to a higher level competition would be based on a minimum number of competitions, and points would be accumulated to determine the top three athletes in that class.
3. Judging is standardized and is based on the individual's horsemanship skill. This is accomplished by judging one athlete or team at a time, on their own merit, performing the identified element, for each class in the competition.

**ARTICLE IV - MEMBERSHIP**

- A. Current Membership:
  - B. Students in grades 9 through 12 interested in competing on an equestrian team shall be eligible for membership providing the student has a team coach/advisor.
    1. Adult advisors, coaches and their assistants shall be eligible for membership. A team coach or advisor shall be considered a 'District Board of Directors' member representing their team at the district level.
    2. Any other administrative person that serves in any capacity and is endorsed by district membership shall be eligible for membership.
    3. All High Schools who have a participating team must have a signature of a High School Administrator approving team participation.
- B. **New Members** - Team application for membership in this association shall be made by fax, Email, or in letter form to the OHSET District Secretary who will present to the District Board for approval and then forward such information (upon approval) to the State Board Secretary who will report the team addition at the next State Board Meeting.
- C. **Withdrawal** - Team withdrawal intent must be submitted to the OHSET District Board of Directors Chairperson and then forward such information to the State Board Secretary who will report the team withdrawal at the next State Board Meeting.
- D. **Readmission** - Shall be the same procedure that governs the admittance of new members.
- E. **Removal** - A team or individual may be dropped from the OHSET by the majority vote of the State Board of Directors based upon OSAA process.

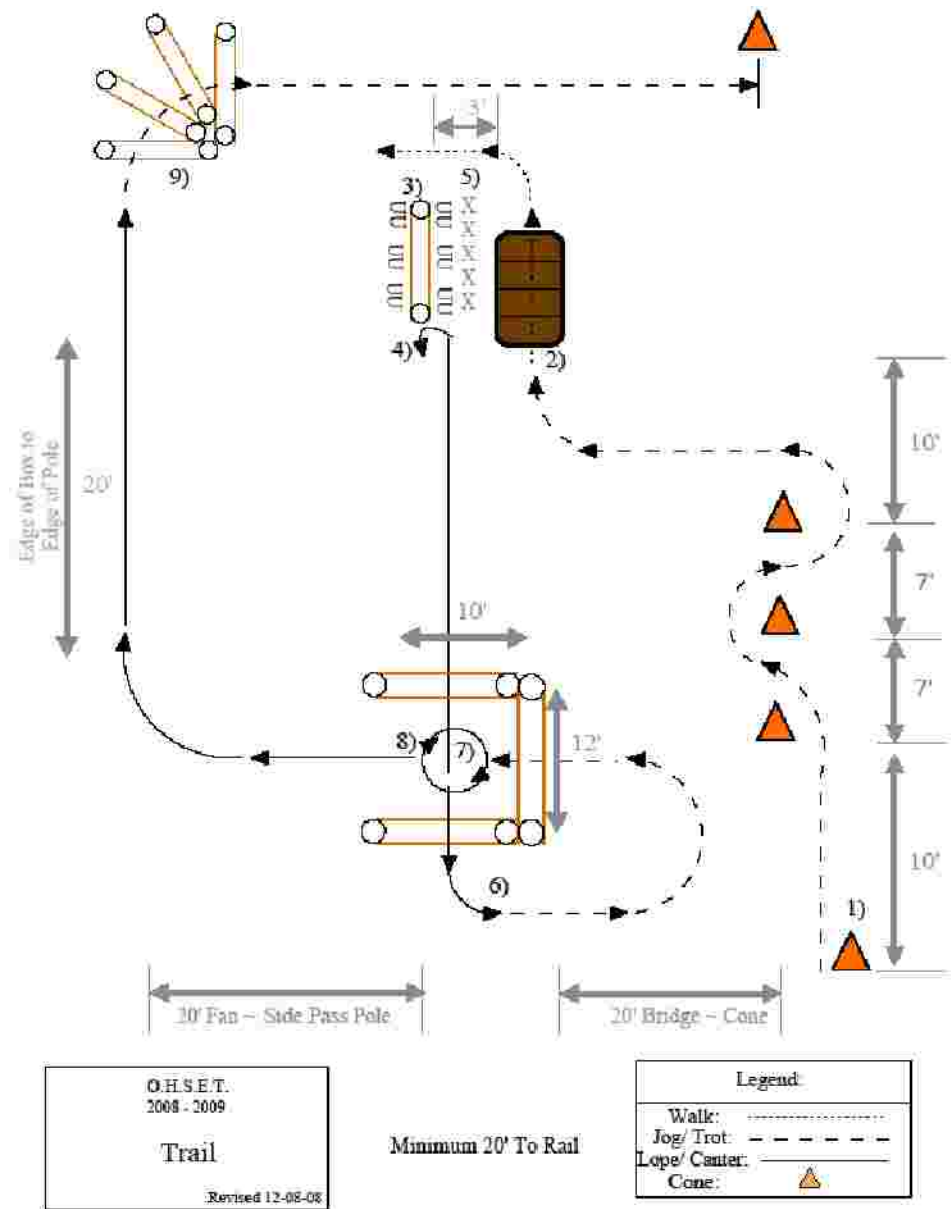

Date: _____ District: _____			
<b>CLASS: TRAIL</b>			
HIGH SCHOOL: _____ ATHLETE #: _____			
<p><b>Expectations:</b> Horsemanship knowledge in displaying fundamentals is important. Accuracy, smoothness and acceptance of obstacles should be points of training. Timing will count. Athlete and equine should create a working team. Movement through and over obstacles should be crisp while allowing the equine to negotiate each step. Leads should be accurate and backing should be precise, but not too slow. Haunch turns, pivots, lateral movements and backing should be smooth with continual movement.</p> <p>Refusals will deduct points. Two refusals will require moving on to the next element.</p> <p>Judges will be looking for a "finished" equine/athlete combination in this event.</p> <p><b>Equipment Needed:</b> 5 cones, 1 – 4x8 bridge, 6 – 10" poles (4, fan &amp; 2 for the 3-sided box), 1 – 8" pole (sidepass), 1 – 12" pole (back of 3-sided box).</p>			
#	ELEMENT JUDGED:	COMMENTS:	SCORE
1.	Jog around cones		
2.	Walk Over Bridge		
3.	Sidepass left over pole		
4.	90 degree left haunch turn and back between pole and bridge		
5.	Left lead lope out and over (3-sided) box		
6.	Transition to jog and stop in box		
7.	360 degree right haunch turn		
8.	Right lead lope out of box and transition to jog		
9.	Jog through fan and halt		
10.	Overall Horsemanship		
Judge's Signature: _____			

Revised 11.06.08

- F. **Membership Voting** - after notification of withdrawal has been reported to the OHSET District Board of Directors or Chairperson, the individual or team dropping shall have no vote unless reinstated.
- G. Student participation eligibility will be determined using OSAA guidelines.

**ARTICLE V - GOVERNING BODY - THE STATE BOARD OF DIRECTORS**

**Section 1. Leadership:**

- A. The leadership of OHSET will be vested in the State Board of Directors.

**Section 2. Purpose:**

- A. The purpose of the State Board of Directors is to support the mission, purpose and goals of the OHSET program.

**Section 3. Duty:**

- A. The State Board of Directors shall be the representative body of the Oregon High School Equestrian Team Association, shall conduct business of the Association, and shall communicate actions and plans to the association members. The State Board shall be empowered to authorize expenditure of the Association funds and activities of the various committees.
- B. Other duties of the State Board are to:
  1. Establish and conduct the OHSET State Competitions
  2. Act in an advisory capacity to assist the Districts in establishing and conducting District Competitions and programs.
  3. Establish criteria; conduct training and certification for OHSET judges.
  4. Communicate OHSET activities and opportunities for youth members and representatives.
  5. Provide recognition to OHSET youth members and representatives.
  6. Assure the OHSET program offers its program and materials equally to all adult volunteers and appropriately aged youth in the State of Oregon.
  7. Establish and publish competition rules.
  8. Amend the Constitution and By-laws as may be necessary in carrying out the provisions of the constitution.
  9. Establish and revise OHSET Districts and their boundaries.

**ARTICLE VI - STRUCTURE - THE DISTRICT AND STATE BOARD OF DIRECTORS**

**Section 1. Membership:**

- A. The membership of OHSET consists of registered competing and non athletes of each high school team, advisor/coach of each high school team and volunteers active at the District or State level.
  - 1. All Persons signing the OHSET Code of Conduct will acknowledge and adhere to OHSET rules and bylaws.
- B. The **voting membership** of the District Board shall be constituted as follows:
  - 1. One (1) coach/advisor or adult representative from each team within the district.
  - 2. Youth representation and voting privileges will be established at the district level. Voting in District meetings will be at the discretion of the District.
- C. The **membership of the OHSET State Board** shall be constituted as follows:
  - 1. District Chair and one (1) Youth Representative from each district, to be elected by the District prior to the June State Board meeting.
  - 2. Any other administrative person that serves in any capacity and is endorsed by State Board membership shall be eligible for membership of the State Board.
  - 3. No more than one (1) adult voting representative from the same school may serve as a member of the State Board at the same time.
  - 4. If a vacancy occurs within the State Board, the District with the vacancy will fill that vacancy. The newly elected member will serve the remaining tenure of the terminated member.
  - 5. Note: The number of Adult Representatives will change with the addition of new Districts. The maximum number of Adult Representatives will be eighteen (18). Upon reaching eighteen (18) the number of district representatives will be reduced to two (2) and then to one (1).

**Section 2. Membership Meetings:**

- A. All District or State Board meetings shall be at such location as designated by the appropriate Board of Directors.

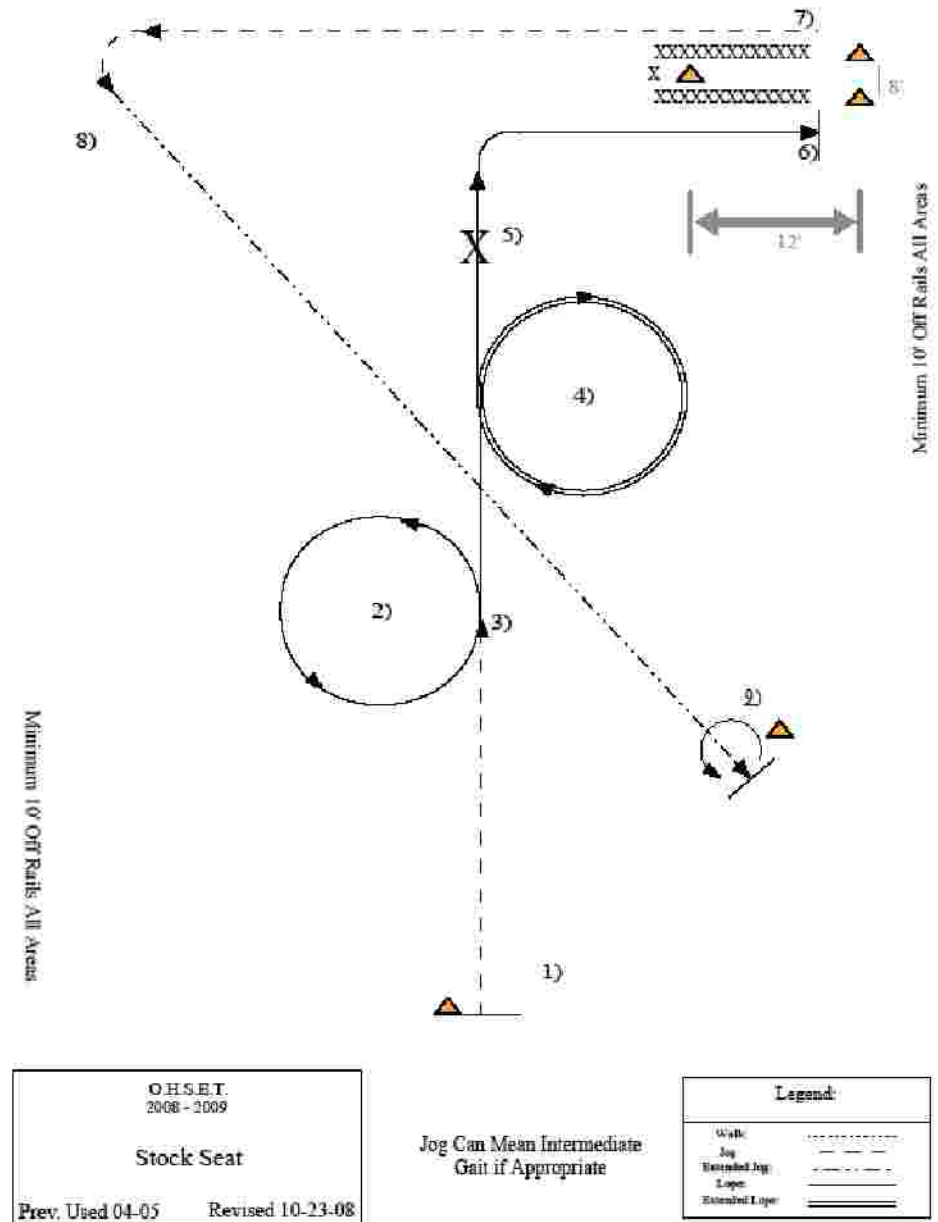

Date: \_\_\_\_\_ District: \_\_\_\_\_

**CLASS: STOCKSEAT EQUITATION**

---

HIGH SCHOOL: \_\_\_\_\_ ATHLETE #: \_\_\_\_\_

Equitation skills in performing smooth elegant maneuvers and transitions score higher. Understanding what the pattern calls for and planning arena space will enhance the performance.

This pattern is asking for the athletes' BEST lead changes. The following is the general guideline for scoring lead changes (the scores are maximum possible if every part of the element including the lead change is perfect):

- Flying Lead Change – maximum possible 10
- Interrupted Lead Change – maximum possible 8
- Simple Lead Change – maximum possible 6

Clearly, the goal is a perfect flying lead change, however, this allows for athletes to work into this maneuver. Remember, perfect means: equitation, hands, change (no steps in an interrupted, few steps in simple, no disunited steps in flying, and so on.)

(This is an equitation class. Body position of athlete is scored; behavior of the equine is the direct result of the athlete's horsemanship skills.)

#	ELEMENT/JUDGE:	COMMENTS:	SCORE
1.	Start at cone and jog down center line.		
2.	Pick up left lead and lope circle to the left.		
3.	On straight line, change to right lead. Correct flying lead change is preferred.		
4.	Extend lope and circle right.		
5.	On center line; collect lope and change to left lead. Continue up centerline and turn corner to the right. (counter canter)		
6.	Stop at cone, back "U" shape ending at opposite cone.		
7.	Pick up jog and continue around corner.		
8.	Extend the jog across diagonal, stop at cone.		
9.	360 degree left haunch turn, wait to be excused.		
10.	Overall Horsemanship		

Judge's Signature: \_\_\_\_\_

Revised 11-05-08

- B. Meetings shall be called as necessary at the District or the State level.
  - C. Special meetings may be called at any time upon request of at least three members of the District or State Board of Directors. Board of Directors and Officers shall be notified at least two (2) days prior to the meeting date unless there is an extreme emergency. Special meetings may be held electronically, for time critical decision making. Electronic meeting decisions will be affirmed at the next regular State Board Meeting.
  - D. Twenty five percent (25%) of the documented general membership (of district for district meeting or State for State meeting) may call a special meeting of the District or the State Board of Directors by notifying any board member. The Board of Directors and Officers shall be notified by certified mail at least ten (10) days prior to the meeting date.
  - E. All District and state meetings are open to any members.
  - F. The Annual State Board of Directors meeting will be held between December 1<sup>st</sup> and February 1<sup>st</sup> with 1-month notice given to all Districts.
  - G. The committee chairperson or the chairperson of the Association will call for committee meetings whenever and as often as deemed necessary to execute the responsibilities of the committee. A progress report of each meeting will be submitted to the appropriate District or State Board of Directors and Officers at their next scheduled meeting.
- Section 3. Election of Officers:**
- A. The Officers of the District Board of Directors shall be elected as desired by the District. The District Director and District Members at Large shall be ready to report to the June State Board meeting as District Representatives.
  - B. The officers of the State Board of Directors shall be elected from the Representatives to the State Board with exception of the Secretary and Treasurer, which are appointed offices. The election shall be by the Representatives present at the June State Board meeting. The elected officers shall assume their duties at the next Board meeting.
- Section 4. Tenure:**
- A. The tenure of the adult Representatives on the State Board shall be two (2) years. One half of the membership shall be replaced each year. Re-election to the State Board by the district is permissible.

- B. The tenure of the youth Representative on the State Board shall be one (1) year. They may be re-elected.
- C. Members will assume their membership on the State Board at the next meeting. Terms will conclude at the June meeting.
- D. Any State Board Representative's term may be terminated for:
  1. Being absent for two (2) consecutive meetings, unless excused by the Chairperson.
  2. Violation of the State Board Constitution, Bylaws and Rules.
  3. Misappropriation of funds.
  4. Written resignation from the Representative.
- E. If a Representative is terminated for any reason, the person chosen to replace will finish out the term for the person they are replacing.

**Section 5. Quorum:**

- A. A quorum shall be those members present at any properly called meeting.

**Section 6. Voting:**

- A. A Board of Director member or person representing their district shall cast one vote at the State Board level.
- B. Voting at the team or district meetings will be at the discretion of the District.
- C. All official decisions, unless otherwise stated in this constitution, shall be by a majority vote of the Board of Directors present and voting. Delegation of votes shall be restricted to members identified at the beginning of the meeting representing their team or district and logged in the meeting minutes. A coach/advisor who is unable to attend meetings must notify by phone or Email the Chairperson, Vice-Chairperson or Recording Secretary prior to said meeting who is to be the voting representative for said team or district.
- D. Proposals need majority vote to pass (over one-half of the quorums).
- E. The Constitution and by-law changes can only be made during the annual meeting. Proposed changes must be submitted in writing to the District Chairperson and sent on to the State Board Secretary, with page number, article or section, 30 days prior to annual meeting to be distributed to the membership prior to the meeting via Email or ground mail to each district. Constitution and By-Laws shall be amended by a two-thirds (2/3) vote of the committee present at the annual meeting provided

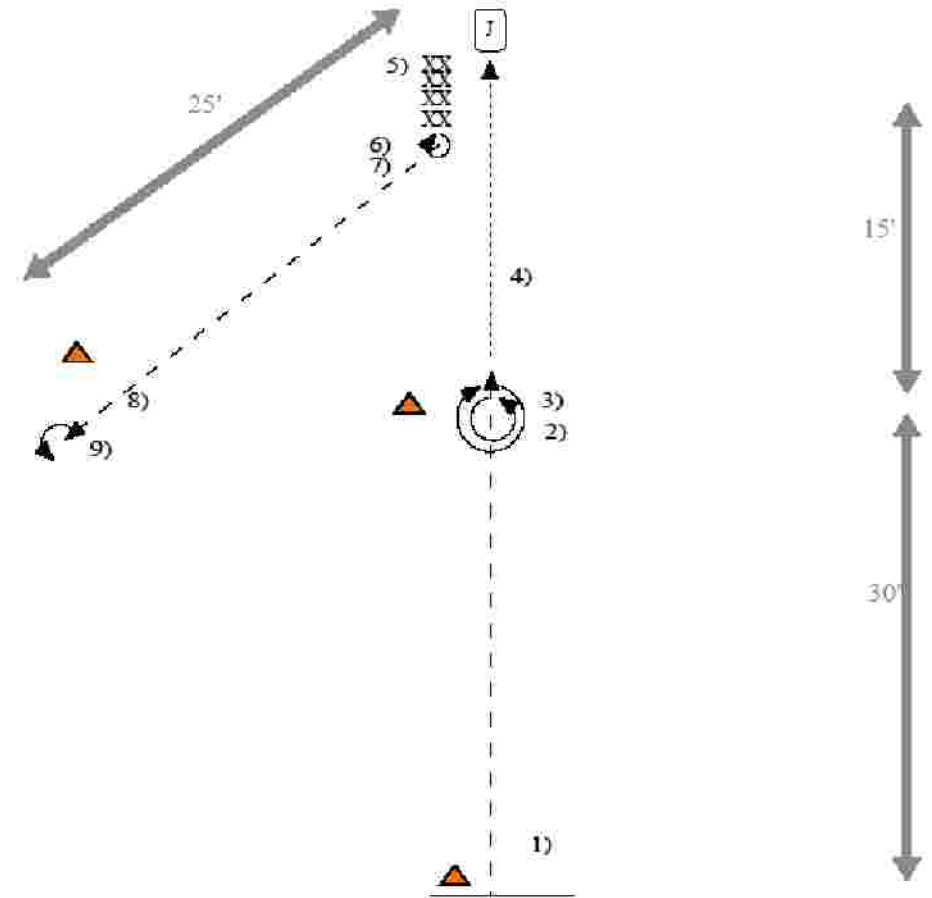

O.H.S.E.T.  
2008 - 2009

**Showmanship**

Prev. Used 03-04      Revised 10-23-08

Legend:	
Walk:	-----
Jog/Trot	- - - -

Date: \_\_\_\_\_ District: \_\_\_\_\_

**CLASS: SHOWMANSHIP**

HIGH SCHOOL: \_\_\_\_\_ ATHLETE #: \_\_\_\_\_

We are looking for the athlete to create a presence that convinces the judge and audience that their horse is the best and that they have successfully completed every element of the pattern. Eye contact with the judge, crisp body communication and facial expression are all part of this ground equitation class.

Changes of sides should show the willingness of the horse to yield to the athlete under any conditions. Condition of coat, feet, mane and tail does count in this class.

Horse should display no resistance – lead rope and halter should be properly adjusted and appear to not be necessary in the horse's performance.

Equipment Needs: 3 cones

#	ELEMENT JUDGED:	COMMENTS:	SCORE
1.	Wait to start at cone, Jog until even with next cone		
2.	Halt, 360 degree left haunch turn		
3.	360 degree right forehand turn; Return to near side		
4.	Walk to judge and set up for inspection		
5.	Back 4 steps; close 1 step		
6.	Approximately 225 degree right haunch turn		
7.	Trot to cone on off side		
8.	Stop, change sides		
9.	90 degree left forehand turn and wait to be excused		
10.	Overall Showmanship		

Judge's Signature: \_\_\_\_\_

Revised 12/08/08

notice of any proposed amendment shall have been given to all members of the State Board not less than two weeks previous to said meeting. All bylaw changes and actions taken at the annual meeting will become effective immediately, including event additions or deletions, board positions, etc.

- F. All Rule changes must be submitted in typed form to the State Board Secretary, with page number, article or section. The whole section will be typed with the change. Proposed changes must be submitted 30 days prior to next State Board meeting to be distributed to the membership prior to the meeting via Email or ground mail to each district. Rules shall be amended by a majority vote of the Board of Directors present at the meeting provided notice of any proposed rule change shall have been given to all members of the State Board not less than two weeks previous to said meeting.

**Section 7. Board of Directors and their duties:**

- A. The officers of the State Board (and Districts if desired) shall consist of Chairperson, Vice Chairperson, Secretary and Treasurer.
1. **Chairperson**
    - a. Elected by the Board.
    - b. Call Board and Special meetings.
    - c. Prepares the agenda.
    - d. Act as General Chairperson of the meetings.
    - e. Appoints Chairpersons of committees as needed.
    - f. Act as Chief Executive Officer of the OHSET.
  2. **Vice Chairperson**
    - a. Elected by the Board.
    - b. Assists the Chairperson in the performance of his/her duties.
    - c. Acts as chairperson in the absence of the Chairperson.
    - d. Assumes temporary responsibilities of any vacated officer's post until the vacated post is filled.
  3. **Secretary**
    - a. Appointed by the Chairperson and approved by the Board and is a non-voting Officer of the Board (unless also acting as a District Chairperson or District Representative).
    - b. Tape-records and keeps minutes of all Board Meetings. Distributes meeting

- minutes via Email or ground mail to all State Board Members
- c. Maintains an updated OHSET School membership list and distributes to State Board and district representatives quarterly as needed.
- d. Keeps an accurate account of State Champions and other pertinent information for the State Association.
- e. Accepts and presents any rule changes to the State Board in the proper format.

**4. Treasurer**

- a. Appointed by the Chairperson and approved by the Board and is a non-voting Officer of the Board (unless also acting as a District Chairperson or District Representative).
- b. Acts as custodian of all OHSET funds.
- c. Keep records of assets, liabilities, income and disbursements. Reports at each meeting, keeping Board updated as to funds.
- d. Acknowledges all contributions.
- e. Submits an annual financial statement to all State Board Directors and Officers.
- f. Responsibility of all bank checking and savings accounts.
- g. Arranges an independent financial review to be performed before installment of new officers at the conclusion of their tenure.
- h. Files an annual tax return.

**Section 8. Standing Committees:**

- A. If a district position is vacated or not filled, the District with the vacancy may appoint another representative to the committee at any time.

**1. Judges Committee**

- a. Shall be appointed by the Association Chairperson under the direction of the State Board of Directors.
- b. Will report to the State Board of Directors and work closely with the Rules Committee.
- c. Will be responsible to:

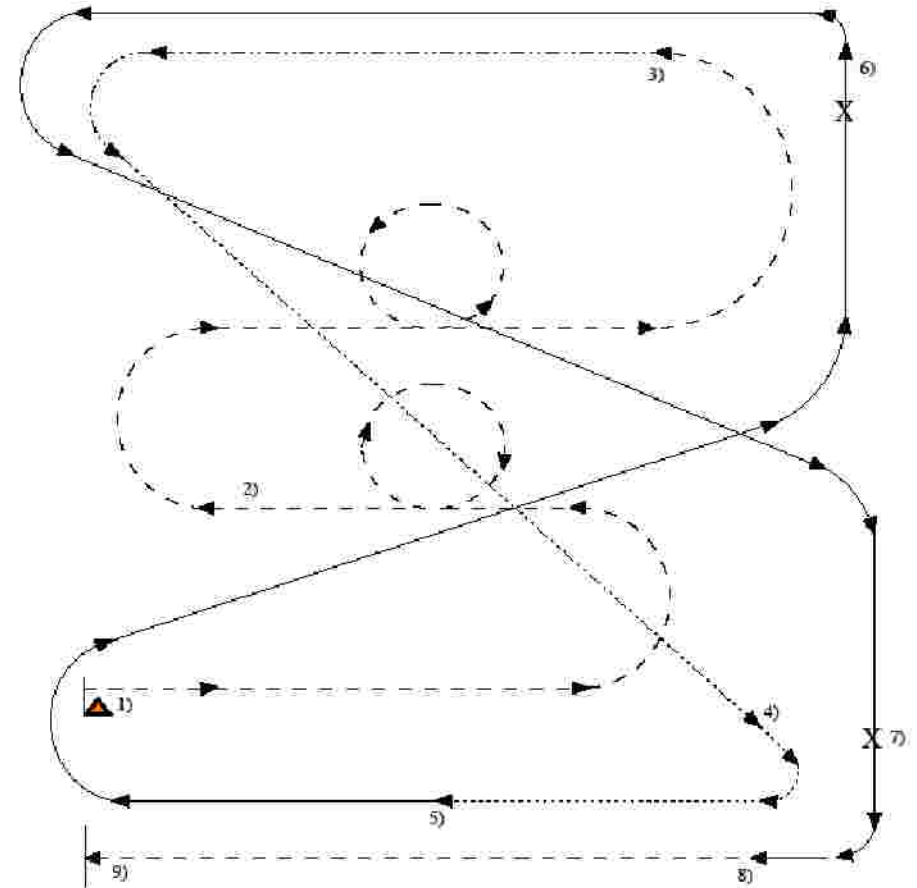

OHSET  
2008 - 2009  
**Saddle Seat**  
Revised 10-23-08

Intermediate Gait is  
Appropriate for Gaited Horses

Legend:	
Walk:	—————
Trot / RT. Gait	- - - - -
Strong Trot /	· · · · ·
Running Walk:	· · · · ·
Canter:	—————

Date: \_\_\_\_\_ District: \_\_\_\_\_

**CLASS: SADDLE SEAT EQUITATION**

HIGH SCHOOL: \_\_\_\_\_ ATHLETE #: \_\_\_\_\_

**Expectations:** Proper body and hand position is of utmost importance, with hands elevated but keeping a straight line between bit and elbows and using light contact with the equine's mouth.

Body position with ear, shoulder, hip, and heel alignment will be closely observed in this pattern.

Use of the arena to best display the equine's ability and athlete's horsemanship will score higher points. Animated movement of the equine with no resistance to hand or leg cues during the pattern, maintaining the ability to collect during lead changes and transitions is going to contribute to the overall success of this performance.

Accelerate and quality lead changes are expected.

**Equipment Needed:** None

#	ELEMENT JUDGED:	COMMENTS:	SCORE
1.	Start at cone, trot/intermediate gait first loop of serpentine to center, circle right in center		
2.	Trot/intermediate gait second loop of serpentine to center, circle left.		
3.	Strong/extended trot/intermediate gait, down rail and across diagonal		
4.	Walk, walk around corner to center		
5.	Canter, right lead around corner and short diagonal line, down rail, counter canter. Change leads before corner (type of change is optional)		
6.	Continue to left around end of arena, and short diagonal line, down rail, counter canter.		
7.	Change leads before corner. (type of change is optional)		
8.	Trot/intermediate gait		
9.	Halt, present your horse for 10 seconds. Wait to be excused.		
10.	Overall Horsemanship		

Judge's Signature: \_\_\_\_\_

Revised 11/06/08

- 1) Develop and maintain criteria for judging OHSET
- 2) Develop an education process for judges to meet OHSET criteria for judging.
- 3) Develop and maintain an approval process for judges to be certified as OHSET judges.
- 4) Maintain an up-to-date judge's list identifying individual events each judge is certified to judge as a resource.
- 5) Design patterns for upcoming year.

**2. Rules Committee**

- a. Shall be appointed by the Association Chairperson under the direction of the State Board of Directors.
- b. Will report to the State Board of Directors and work closely with the Judges Committee.
- c. Will be responsible to:
  - 5) Review, develop and modify the OHSET rules;
    - (a) Utilizing National Standards for events as able
    - (b) With input from the judges' committee and the State Board
    - (c) With Youth as the focus
    - (d) And an emphasis on Safety.

**ARTICLE VII - IMMUNITY OF MEMBERS**

Neither the members of the Association, nor Standing Committee members, nor members of the State Board of the Association shall be personally liable for any of the debts, liabilities or obligations of the Association.

**ARTICLE VIII – ASSETS DEDICATED TO AN EXEMPT PURPOSE**

- A. No substantial part of the activities of the organization shall be the carrying on of propaganda, or otherwise attempting to influence legislation and the organization shall not participate in, or intervene in any political campaign on behalf of any candidate for public office.

- B. Notwithstanding any other provision of this document, the organization shall not carry on any other activities not permitted to be carried on:
1. By an organization exempt from federal income tax under section 501 (c) (3) of the Internal Revenue Code, or the corresponding section of any future federal code, or
  2. By an organization, contributions to which are deductible under section 170 (c) (2) of the Internal Revenue Code or the corresponding section of any future federal tax code

**ARTICLE IX - FISCAL POLICY**

All funds obtained by this Association shall be expended at the discretion of the State Board for the benefit of the e and future Oregon High School Equestrian Teams. No funds will be expended for the personal gain of any member of this Association. No part of the net earnings of the organization shall inure to the benefit of, or be distributable to its members, trustees, officers, or other private persons, except that the organization shall be authorized and empowered to pay reasonable compensation for services rendered and to make payments and distributions in furtherance of the purposes set forth in the purpose clause hereof.

**Section 1. Dissolution:**

- A. In the case of dissolution of this Association, all funds not specifically earmarked for approved expenditure will be given to the Equestrian Special Olympics, a not for profit organization. However, if the named recipient is not then in existence or no longer a qualified recipient, or unwilling or unable to accept the distribution, then the assets of this organization shall be distributed to a fund or foundation which is organized and operated exclusively for the purposes specified in section 501 (c) (3) of the Internal Revenue Code.
- B. Upon the dissolution of the organization, assets shall be distributed for one or more exempt purposes within the meaning of section 501 (c) (3) of the Internal Revenue Code, or corresponding section of any future federal tax code, or shall be distributed to the federal government, or to a state or local government, for public purpose. Any such assets not disposed of shall be disposed of by the Court of Common Pleas of the county in which the principal office of the organization is then located exclusively for such purposes to such organization or

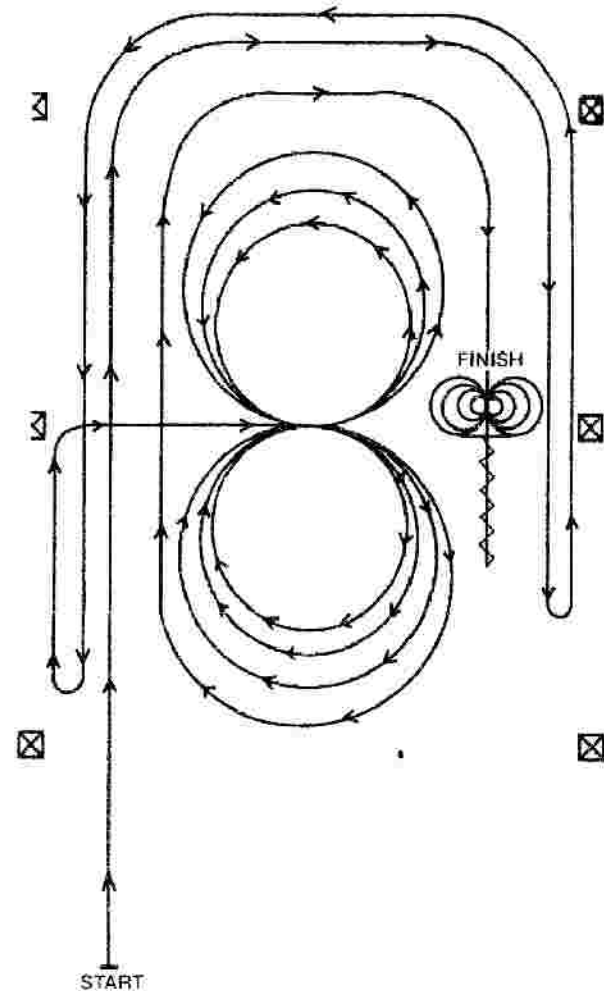

O.H.S.E.T.  
2008 - 2009

Reining

(NRHA #3) Revised 10-07-08

Date: _____ District: _____			
<b>CLASS: REINING (NRHA Pattern #3)</b>			
HIGH SCHOOL: _____	ATHLETE #: _____		
Pattern will take 5-7 minutes.			
Expectations:			
<b>Equipment Needed: 6 cones</b>			
<b>#</b>	<b>ELEMENT JUDGED:</b>	<b>COMMENTS:</b>	<b>SCORE</b>
1.	Lope straight up the left side of the arena, circle the top end of the arena, and staying at least 20' from the walls or fence, run straight down the opposite or right side of the arena past the center marker and do a left rollback - no hesitation.		
2.	Continue straight up the right side of the arena circle back around the top of the arena, and staying at least 20' from the walls, run straight down the left side of the arena past the center marker and do a right rollback - no hesitation.		
3.	Continue up the left side of the arena to the center marker. At the center marker, the horse should be on the right lead. Guide the horse to the center of the arena on the right lead and complete three circles to the right: the first two circles large and fast, the third circle small and slow.		
4.	Change leads in the center of the arena, (flying lead change expected and preferred)		
5.	Complete three circles to the left: the first two circles large and fast; the third circle: small and slow.		
6.	Change leads in the center of the arena, (flying change expected and preferred)		
7.	Begin a large fast circle to the right, but do not close this circle, continue up the left side of the arena, circle the top of the arena, staying at least 20' from the walls, run straight down the opposite or right side of the arena past the center marker and do a sliding stop. Buck at least 10'. Hesitate.		
8.	Complete 4 spins to the right; hesitate.		
9.	Complete 4 spins to the left. Wait to be excused.		
10.	Overall Horsemanship (Ok to dismount before exit)		
Judge's Signature: _____			

Revised: 11.05.08

organizations, as said Court shall determine which are organized and operated exclusively for such purposes.

**Section 2. Fiscal Year:**

A. The fiscal year for the organization will be from July 1<sup>st</sup> to June 30<sup>th</sup>.

**Section 3. Yearly Budgets:**

A. All Districts and the State Board are required to file a yearly budget and a bi-annual financial statement with the State Board Treasurer. Reports should cover:

- 1, January 1<sup>st</sup> thru June 30<sup>th</sup>
2. July 1<sup>st</sup> thru December 31<sup>st</sup>

Last review: **December 1, 2007**



PATTERSON  
ENGRAVING

LASER ENGRAVING SERVICES & PRODUCTS

GIST BUCKLES    TROPHY SADDLES    PET MEMORIALS

AWARDS    SIGNS & BANNERS    BADGES

Chuck Patterson  
iblastrock@gmail.com    **541-390-0382**



5711 GAFFIN RD SE.  
SALEM, OR 97301

**STEVE & MARY ANN PATTERSON**

**PH: 503-585-7140 • FAX: 503-585-1753**

**We can take care of all of your**

horses needs:

- Grain
- Hay
- Tack

You will find a large selection of clothing, boots and jewelry!  
Be sure to check out our Bling Bling collection!

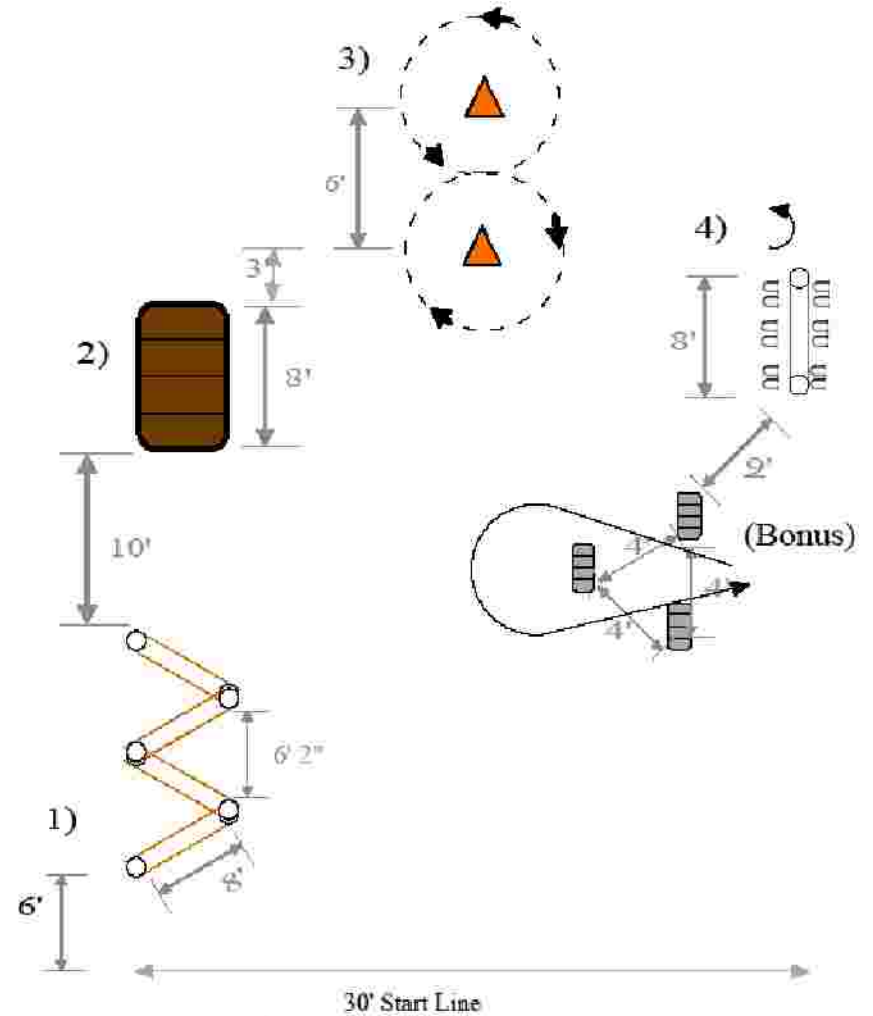

O.H.S.E.T.  
2008 - 2009  
**In-Hand Obstacle Relay**  
Revised 12-8-08

Legend:	
Walk:	.....
Jog/ Trot:	- - - - -
Backing:	—————
Cone:	▲

Date: \_\_\_\_\_ District: \_\_\_\_\_

**CLASS: IN HAND OBSTACLE RELAY**

ATHLETES: \_\_\_\_\_, \_\_\_\_\_, \_\_\_\_\_  
 HIGH SCHOOL: \_\_\_\_\_ TEAM: \_\_\_\_\_

**Expectations:**  
 This is a horsemanship class! Equine and athletes should be properly groomed as in a Showmanship Class.  
 Maneuvers should be crisp and practiced. Only the very best should attempt the "BONUS" obstacle element.  
 Equine should show no resistance to handler during any maneuver and should appear as if on a lead rope.  
 Equine should move quickly, but maintain the superior ground manners that one would expect in a showmanship class.

**Equipment Needed:** Chalk line will be placed between start poles/obstacles, 4x8" bridge, 2 cones, 5, 8' pole (3-6" diameter), 3 barrels

Obstacle:	Handler 1:	Handler 2:	Handler 3:	Handler 4:
Trot Over Zig Zag				
Walk Over Bridge				
Trot Fig 8, Right to Left				
180 degree left haunch turn, Sidepass pole left				
<b>Optional, Back through 2 barrels around 3<sup>rd</sup> barrel - counter clockwise</b>				
Penalty Points				
Total points = handler minus penalty points				
Total Time:	1 assessment per team		Penalty Points:	
			Total Team Points:	
Judge's Signature: _____				

Revised 11.05.08

### OHSET Advisor/Coach Role Expectations

**Registered Team Advisor:** Must be 21 years old or older.  
 (Requirement for every team)

- 1) Organizes team to meet the mission, purpose and goals of the OHSET program.
- 2) Liaison with High School. Understands High School requirements for athlete participation, i.e. code of conduct, grade requirements.
- 3) Represents team at the district board meetings or ensures a delegate attends.
- 4) Utilizes Communication guidelines and includes the District Chairperson in issues as appropriate to promote fairness within the district.
- 5) Clear understanding of OHSET rules, policies and guidelines.
  - a) Acts in an advisory capacity to assist the coaches, athletes, parents and volunteers in participating according to rules, policies and guidelines.
- 6) Identifies in writing, clear expectations of team regarding conduct, attendance, lettering requirements, practices, participation in fundraising, official OHSET functions etc.
- 7) **Team Rules:** Required to have a copy of their team rules on file with the district each year. These will be turned in "annually" with the registration of each school team.
- 8) **School Code of Conduct:** Required to submit a copy of the School Code of Conduct. This will be included with the submission of Team Rules to the district. **Purpose:** Immediate resolution of issues that concern disbursement of money, code of conduct infractions and they can be used to back up legal inquiries.
- 9) **Complete Team Registration:**
  - a) Ensures Team approval from high school via a signature of a High School Administrator approving team participation.
  - b) Ensures information on all adult coaches meet OHSET and high school requirements
  - c) Ensures complete registration of all athletes including medical insurance,
- 10) Signs code of conduct, school requirements met, and maintains appropriate paper work at all OHSET functions.
  - a) Personally signs a Code of Conduct & Release Form.
  - b) Requires all participants, i.e. coaches, volunteers, etc., to sign **Code of Conduct & Release Form.**

- 11) Provide situations where each equestrian team member:
- Can be exposed to cooperative working experiences that lead to common group goals.
  - Can experience good leadership opportunities, fair play, horsemanship, honesty, character, pride and good sportsmanship at all times.

**Registered Team Head Coach-** Must be 21 years old or older.  
(Requirement for every team)

- In conjunction with Advisor, outlines expectations in writing for athletes, for practices, lettering requirements, etc.
- Provides practices within the OHSET season beginning Dec.1st and concluding after State, Regional, or National Competition.
- Selects teams or varsity/junior varsity athletes **after** Dec 1<sup>st</sup>.
- Provides, conducts and hosts equestrian interscholastic programs with proper instruction, coaching methods and conditioning rules, in order to insure the health, safety and welfare of each participant and equine.
- Encourages athlete leadership.

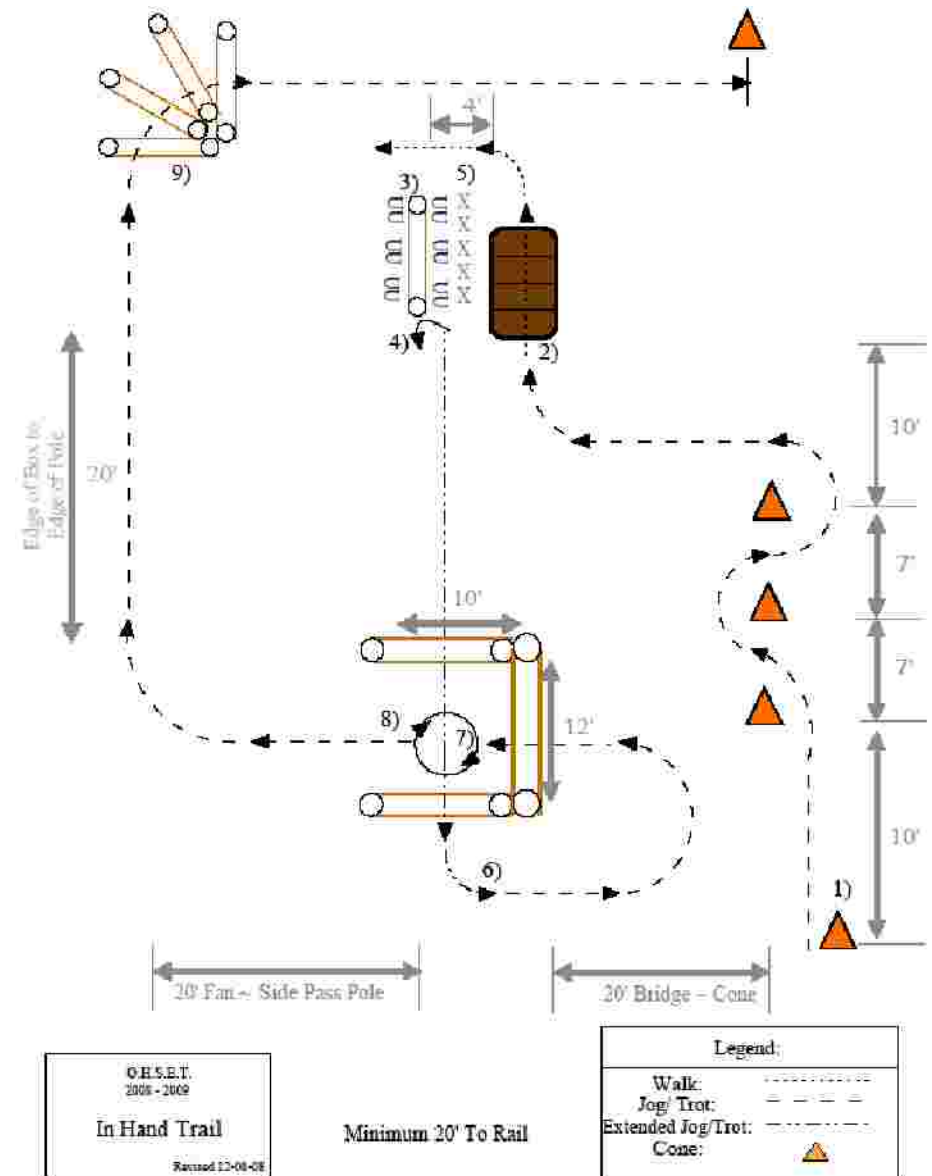



**"Trifecta" 3 in 1 Supplement for Your Horse,  
Joint, Hoof & Hair Health and Vitamins**

**We Stock Strongid C2X Continuous Wormer**

**New Stock of Water Proof Horse Blankets,  
Breeches and Tops!**

22525 SW Stafford Road  
Tualatin Oregon 97062

Linda Dorie  
503-973-0114

One stop shopping for all your horse care, feed, supplements and vitamins

**Code of Conduct Standards & Violation Procedures  
Organizational Goals and Affiliations**

Oregon High School Equestrian Teams (OHSET) has as its main goal the recognition in the high schools of the equestrian athlete and to give them an opportunity to achieve that recognition in a fair, positive and educational format. The goals are to encourage team play, peer acceptance and good horsemanship. Competition is to follow sportsmanship guidelines as set down by Oregon School Activities Association (OSAA) and the Oregon State School Board as well as the individual participating s y guidelines and equine sportsmanship guidelines as set forth in the USEF.

**OHSET Code of Conduct Standards**

I. All athletes participating, volunteers associated with d persons contracted with OHSET during the OHSET season, will comply with OHSET Code of Conduct Standards. (All persons associated will be called member throughout this document unless specifically identified.)

**Each Team shall take reasonable measures to insure supporters (friends, relatives, volunteers) of their Team conduct themselves according to OHSET CODE OF CONDUCT STANDARDS.**

II. **Standards of conduct will be applied in the following order:**

**A. School**

1. Athletes shall comply with the written rules of their school district, pursue the prescribed course of study, submit to lawful authority of principal, athletic or activity director, teachers, advisors and coaches and conduct themselves in an orderly fashion.
2. Notification to District Management is required when an athlete is unable to participate in an OHSET activity due to a Code of Conduct infraction with the school. Specifics are not to be documented, but the occurrence should be as it could affect additional infractions issued by either the school or OHSET. The athlete's confidentiality must be considered.

**B. OHSET**

1. The School Code of Conduct applies first
2. If the school code of conduct does not apply, OHSET code of conduct does.

Date: _____ District: _____			
<b>CLASS: IN HAND TRAIL</b>			
HIGH SCHOOL: _____ ATHLETE #: _____			
<p><b>Expectations:</b></p> <p>Athlete and equine should create a working team. Movement through and over obstacles should be crisp while allowing the equine to negotiate each step. Accuracy, smoothness and acceptance of obstacles should be points of training. Timing will count.</p> <p>Haunch turns, pivots, lateral movement and backing should be smooth with continual movement.</p> <p>Refusals will deduct points. Two refusals will require moving on to the next element.</p> <p>It should appear that the equine is working without the use of a lead rope exhibiting no resistance. Judges will be looking for "finished" equine/athlete team.</p> <p><b>Equipment Needed:</b> 5 cones, 1 – 4x8 bridge, 6 – 10' poles (4, fan &amp; 2 for the 3-sided box), 1 – 8' pole (sidepass), 1 – 12' pole (back of 3-sided box).</p>			
#	ELEMENT JUDGED	COMMENTS	SCORE
1.	Jog Around Cones		
2.	Walk Over Bridge		
3.	Side Pass Left Over Pole		
4.	90 degree left haunch turn and back between pole and bridge		
5.	Extended jog between bridge and pole and through (3-sided) box		
6.	Transition down to jog and stop in box		
7.	360 degree right haunch turn		
8.	Jog		
9.	Jog through fan, halt at cone		
10.	Overall Handling		
Judge's Signature: _____			

Revised 11.06.08

- a) Oregon School Activities Association (OSAA) will be utilized as guidelines when appropriate.

III. **We endorse and promote the following values and conduct in order to achieve the OHSET mission:**

- A. High expectations for students, school staffs, advisors, coaches, parents, families, volunteers, communities and spectators
- B. Strong leadership;
- C. Teamwork;
- D. Clear expectations and communication;
- E. Accountability
- F. Athlete Attire (refer to general rules 2.4 Athlete Uniform)
- G. Lifelong learning and skill building;
- H. Recognition of, and rewards for, excellence;
- I. Community & family participation and support;
- J. Safe, orderly learning environments;

IV. **Misconduct includes, but is not limited to:**

- A. Persistent failure to comply with rules, code of conduct or the directions of OHSET officials.
- B. Failure to treat other members in a courteous manner.
- C. Profane or abusive language.
- D. Theft, damage or destruction of property at an OHSET activity.
- E. Intentional cheating.
- F. Assaults or threats of harm to people, animals or property.
- G. Unlawful addictive behaviors, including but not limited to, narcotics, alcohol, tobacco, etc.
- H. Directions from audience while athlete is performing patterns are strongly discouraged.
- I. Abuse, misuse or neglect of equine.

1. **Article GR302 of USEF has issued guidelines identifying specific cruelty and abuse acts. The following acts are included, but are not limited to:**

- a) Excessive use of a whip or spurs on any equine .
- b) Any striking of the equine’s head (on the poll and forward of the poll) with the whip shall be deemed excessive.
- c) Inhumane treatment of an equine in a stall, runway, schooling area, competition ring or elsewhere.

**Hunt Seat Equitation Over Fences Equipment List**

Jump #1 – Vertical with cross poles

- 2’ 6” – 2’8” in height
- 2 Standards
- 4 rails (1 across the top, 2 crossed below, 1 ground line)
- 4 cups

Jump #2 & 6 – Picket Fence

- 2’6” – 2’8” in height
- 2 Standards
- 0-3 poles depending on design

Jump #3 & 7 – ¼ Round 2/green turf

- 2’7” – 2’9” in height
- 2 Standards
- ¼ round
- 0-2 rails (probably doesn’t need a ground line, but likely will need a rail on top – depends on set up)

Jump #4 – Panel

- 2’6” – 2’8” in height
- 2 Standards
- 1-3 rails (needs a ground line, may or may not need rails over the top)

Jump #5 – Panel

- 2’7” – 2’9” in height
- 2 Standards
- 1-3 rails (needs a ground line, may or may not need rails over the top)

Jump # 8a – Post & Rail with Flower Box

- 2’7” – 2’9” in height
- 2 Standards
- 1-3 rails (depends on set up and equipment – could be one or two rails across the top and a ground line)

Jump #8b – Oxer (Post & Rail)

- 2’7” – 2’9” in height and width
- 4 Standards
- 4 rails (depends on set up, needs ground line and second rail in front)

**All fences should be 10-12 feet wide, unless otherwise specified.**



## Yamhill County Fairgrounds

2070 N.E. Lafayette Ave; McMinnville, Oregon 97128  
503-434-7524

**WELCOME TO THE YAMHILL COUNTY FAIRGROUNDS,  
HOME OF THE OLDEST COUNTY FAIR IN OREGON!**

We are PROUD to be called home to several of the  
OHSET Districts in and around NW Oregon.

At our facility we have 5 Horse Barns – 1 is for our Permanent Boarders. The barn used for Permanent Boarders is called the Kadell Barn and is fully lighted with tie rings for grooming and tacking. Each boarder will get a tack stall included. Our fees for Self-Care Boarding are \$130.00 a month.

Delashmutt Indoor Arena is 100'x200' and is ready for your Horse show, gaming event, rodeo or OHSET competition.

Drader Covered Outdoor Warm-up Arena is adjacent to The Delashmutt Arena and is an 80'x100' lighted arena.

Whitman Outdoor Rodeo Arena is 200'x300'  
and is a seasonally used arena.

We have an excellent staff at our facility that strives to Maintain the grounds and buildings. We are constantly trying to improve upon what we have for your benefit.

Please check out our web site [www.co.yamhill.or.us/fair/index.asp](http://www.co.yamhill.or.us/fair/index.asp) for date availability and other information. You can email us at [fair@co.yamhill.or.us](mailto:fair@co.yamhill.or.us)

The Yamhill County Fairgrounds wishes  
Much success and Good Luck  
to all of the OHSET participants!

- d) Excessive jerking of hands that leads to bleeding.
2. **Cruelty – A Matter Of Perspective**
  - a) Many common practices and training methods may appear abusive. Are whips, spurs and sweat the instruments of cruelty? Maybe, maybe not, depending on the observer.
    - (1) If we do not police ourselves, someone else may do it for us.
    - (2) As you train your equine remember that you are the ambassador for all of us involved with equines.
  - b) Cruelty and abuse may be unintentional or a matter of degree. To determine if an action is abusive or cruel, examine your actions and ask yourself the following questions:
    - (1) Am I asking my equine to give more than it is mentally or physically capable of giving?
    - (2) Do my training methods depend on devices to achieve a “look” or quick fix?
    - (3) When I must use punishment, is it used fairly? Am I striking in anger or frustration? Am I using the lightest aid to achieve a desired action?
    - (4) Do I use pain or fear as a training method?
    - (5) What will be the long-term effect on my equine?
3. **If cruelty is reported, it will be investigated.** Appropriate action will be taken and if cruelty or abuse persists, it will be reason for elimination at that event/class. \*See Violation Procedure
- V. **These are considered minimum standards of conduct.**
  - A. It is required that each Registered Team Coach/Advisor contact their high school and get a written copy of their code of conduct.
    1. The written High School Code of Conduct will be discussed with athletes, parents and volunteers and included as part of signing Code of Conduct & Release form.
    2. If the high school does not have a written code of conduct, ask them the process utilized if an athlete, (football, basketball, etc), exhibits misconduct behaviors. Then put this process in

writing, discuss it with athletes, parents and volunteers and include as a part of signing the Code of Conduct & Release form.

- B. Each advisor/coach has the right to formulate additional requirements concerning student conduct while under the direct supervision of the advisor/coach.
1. It is required that expectations be written, discussed with athletes, parents and volunteers and included as part of signing Code of Conduct & Release form.



## Herdener Family Clinic

Dr. Larry J Herdener  
Naturopathic Physician

340 NE Evans Street McMinnville, Oregon  
503-434-6170 herdenerfamilyclinic.com

Treating: \*Back Pain  
\*High Blood Pressure  
\*Menopause Symptoms  
\*Weight Loss

(Visit our website for a complete list of conditions)

Using Natural Therapies to help patients since 1983.  
Give us a call to see if we can help you!

Minimum of 6' off rail

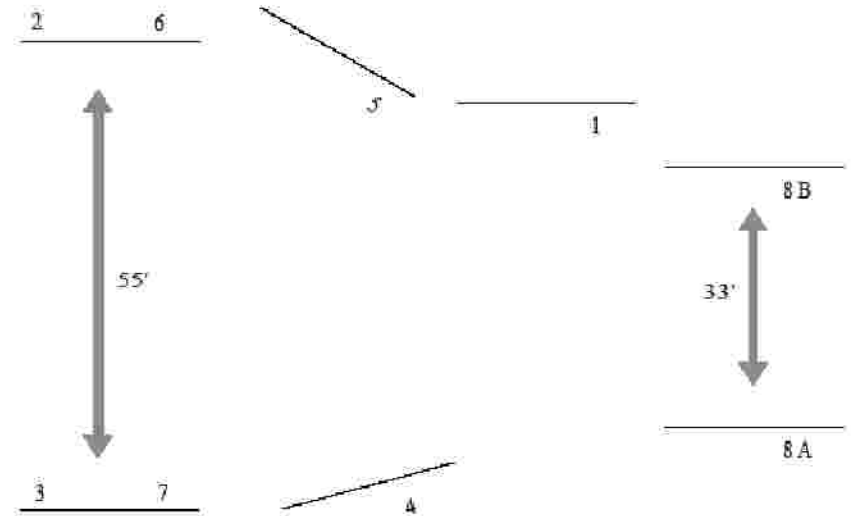

Minimum of 6' off rail

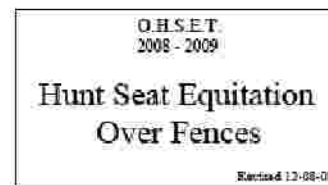

Enter

Revised 12-08-08

Date: \_\_\_\_\_ District: \_\_\_\_\_

**CLASS: HUNTSEAT EQUITATION OVLRFENCES**

HIGH SCHOOL: \_\_\_\_\_ ATHLETE #: \_\_\_\_\_

**Expectations:** Athlete should have a workmanlike appearance, seat and hands being light and supple, conveying the impression of complete control.

Hands should be above and in front of equine's withers, thumbs thirty degrees inside the vertical, hands slightly apart and making a straight line from equine's mouth to athlete's elbow. Reins may be held to inside or outside of little finger. Bight of reins may fall on either side. Athlete should keep light and consistent contact with equine's mouth.

In basic position the eyes should be up and looking toward the next fence. Toes should be at an angle best suited to the athlete's conformation. Ankles should be flexible, heels down, calf of leg in contact with saddle and slightly behind the girth. Iron should be on the ball of the foot and must not be tied to the girth.

At slower gaits there should be a near-straight line from the athlete's shoulder, through the hip, down to the heel. The shoulders should be a couple of degrees in front of the vertical at a Canter, Hand Gallop and when jumping.

The performance begins when the athlete is given the signal to proceed after entering the arena (one circle is allowed before approaching the first fence).

At the Judge's discretion, an eliminated athlete may jump an additional fence, but may not continue thereafter.

#	ELEMENT JUDGED:	COMMENTS:	SCORE:
1.	Setup and Approach 1 <sup>st</sup> Jump, Vertical wirecross poles (height: 2'6"-2'8")		
2.	2 <sup>nd</sup> Jump, Picket fence (height: 2'6"-2'8")		
3.	3 <sup>rd</sup> Jump, ¼ round (height: 2'7"-2'9")		
4.	4 <sup>th</sup> Jump, Panel (height: 2'6"-2'8")		
5.	5 <sup>th</sup> Jump, Panel (height: 2'7"-2'9")		
6.	6 <sup>th</sup> Jump, Picket fence (height: 2'6"-2'8")		
7.	7 <sup>th</sup> Jump, ¼ round (height: 2'7"-2'9")		
8.	8A Jump, Post & Rail/Flower box (Height: 2'7" - 2'9")		
9.	8B Jump, Oxer post & rail (Height: 2'7" - 2'9")		
10.	Overall Equitation		
Judge's Signature: _____			

Revised 11.05.08

**OHSET RULES**

**OHSET Rules and Guidelines will take precedent over all other rules.** However, USEF, WHO, OHA, USDF, OWDTA rules will support OHSET if rules are not covered in the OHSET rules and guidelines.

Supporting Rule Books listed with classes if applicable.  
Rule Books listed in governing order *after* OHSET Rule Book.

**List of class events of competition available:**

**Individual Event Pattern Classes:**

- Showmanship (USEF, OHA)
- Stock Seat Equitation (USEF)
- Dressage (USDF, USEF)
- Working Rancher (OHSET)
- Reining (USEF)
- Saddle Seat Equitation. (USEF)
- Hunt Seat Equitation Over Fences. (USEF)
- Hunt Seat Equitation (USEF)
- Driving (USEF, OHA)
- In Hand Trail (OHSET)
- Trail (USEF)

**Individual Event Timed Classes:**

- Keyhole (WHO)
- Barrels (WHO)
- Breakaway Roping (OHSET)
- Pole Bending (WHO)
- Figure 8 (WHO)
- Steer Daubing (OHSET)
- Individual Flags (WHO)

**Team Classes:**

- Team Penning (OHSET)
- Team Canadian Flags (WHO)
- In Hand Obstacle Relay (OHSET)
- Two Man Birangle (WHO)
- Working Pairs (OHSET)
- Drill Team - Working Fours (OWDTA)

**Drill Team - Short Program (OWDTA)**



- ☑ Providing team and corporate apparel to sports teams, schools and corporations
- ☑ A local company in business since 1992
- ☑ Our screen printer's and embroiderer's have over 30 years experience
- ☑ We have an outstanding reputation of quality products and service at affordable prices
- ☑ Our in-house art department will work with you to create the perfect logo to get your team or company noticed
- ☑ We look forward to working with you on all of your apparel needs!

**Val Kirchem: 503 201 7546**  
**Karla Schumaker: 503 781 9122**  
**vkdesigns@aol.com**

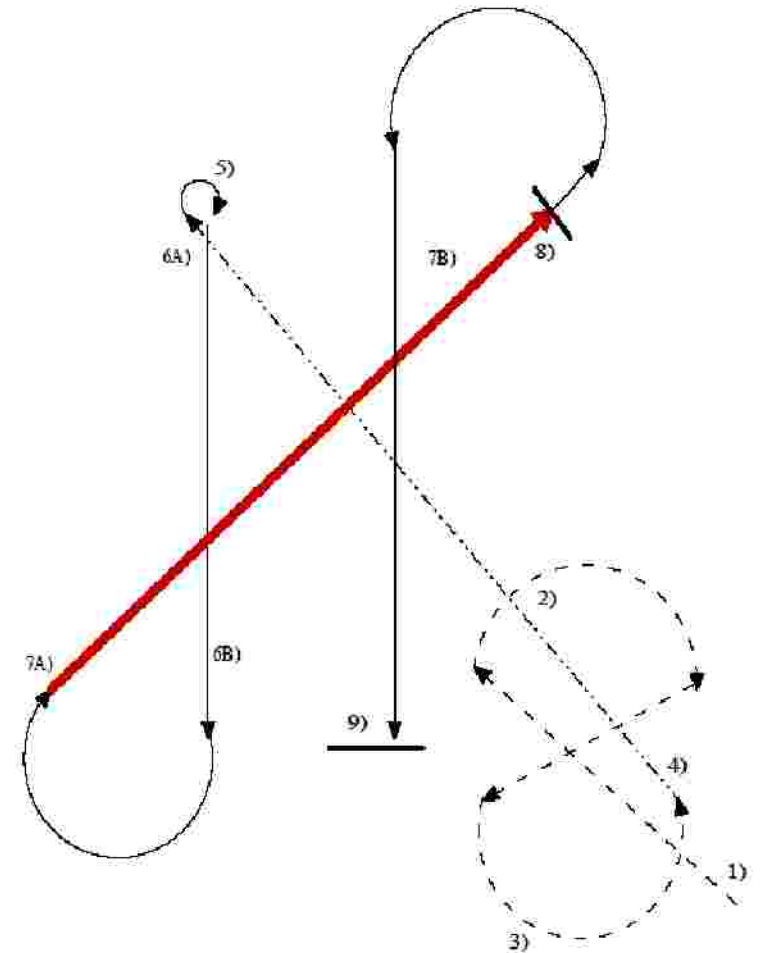

OHSET  
 2008 - 2009  
**Hunt Seat Equitation**  
 Revised 10-23-08

Legend:	
Walk:	.....
Pouring Trot:	- - - - -
Extended Trot:	.....
Canter:	—————
Hand Gallop:	<b>—————</b>

**OHSET Official Contact and Rule Book  
Information**

**Contact and General Information:**

Oregon High School Equestrian Teams website [www.ohset.com](http://www.ohset.com)

District and School Contact Information are available on this website.

*All Communication should be directed through your district chair.*

**State Chair**

**Candi Bothum** ~ 541-419-6350

[EquineConnect@gmail.com](mailto:EquineConnect@gmail.com)

1929 NE Walnut Dr.

Redmond, OR 97756

**Rules Chair:**

**Karen Bragg** ~ 503-682-4982, cell 503-887-7273

[kbragg@paintedvalley.com](mailto:kbragg@paintedvalley.com)

**Katie Stodick** ~ 503-682-4982, cell 503-951-3468

[kstodick@paintedvalley.com](mailto:kstodick@paintedvalley.com)

**Judges Chair:**

**JoAnn Oswald** ~ 503-623-6559, 503-623-8977

[oswald99@yahoo.com](mailto:oswald99@yahoo.com)

**The following rulebooks are used as reference for OHSET District and State Competitions:**

**USEF Inc.**

*(United States Equestrian Federation)*

4047 Iron Works; Parkway, Lexington, KY 40511-8483

(859 )258-2472 ~ [www.equestrian.org](http://www.equestrian.org)

If you are seeking rule clarification, please contact the appropriate discipline for which you are inquiring.

**OHA** *(Oregon Horsemen Association)*

C/O Kim Harrison, (Secretary)

7971 Liberty Rd. S.; Salem, OR 97306

(503) 507-1506~ [www.oregonhorsemen.com](http://www.oregonhorsemen.com)

**WHO** *(Western Horsemen of Oregon)*

Contact WHO President

[President@westernhorsemenoforegon.com](mailto:President@westernhorsemenoforegon.com)

<http://westernhorsemenoforegon.com>

**USDF** *(United States Dressage Federation)*

4051 Iron Works Parkway; Lexington, KY 40511

(859)971-2277 ~ [www.usdf.org](http://www.usdf.org)

**OWDTA** *(Oregon Woman's Drill Team Association)*

Date: _____ District: _____			
<b>CLASS: <u>HIUNTSEAT EQUITATION</u></b>			
HIGH SCHOOL: _____	ATHLETE #: _____		
<b>Expectations:</b> Seat and hands light & supple Reins either inside or outside little finger Eyes up, looking toward next maneuver Iron on ball of foot At walk & trot, there should be a near straight line from the shoulder to the hip, to the heel. At canter and hand gallop, shoulders should be a couple degrees in front of the vertical Flying changes - Max. 10 points; Simple changes - Max. 8 points.			
#	ELEMENT JUDGED	COMMENTS	SCORE
1.	Drop irons: Posting trot, right diagonal without irons, change to the correct diagonal at X		
2.	Posting trot "bow tie" with diagonal changes at X		
3.	Pick up irons while posting the trot		
4.	Extended Trot		
5.	Halt, Approximately 225 degree right forhand turn - until facing appropriate direction		
6.	A) Canter Left Lead B) Change to right lead (before corner and reverse through corner this maneuver should be 10 meters or more.		
7.	A) Hand Gallop B) Collect the Canter		
8.	Before the corner, change to left lead and reverse the corner at the canter		
9.	Halt, settle and stand for 5 seconds. Wait to be excused.		
10.	Overall Equitation		
Judge's Signature: _____			

Revised 7.3.08/08

## RULE INTERPRETATION

### 1.1. Judges

- 1.1.1. Judges' decisions are final in all cases under the scope of their responsibility.

### 1.2. Rule Reference

- 1.2.1. Oregon High School Equestrian Teams (OHSET) Rules and Guidelines have been formulated specific to OHSET competition and these rules shall prevail.
- 1.2.2. The OHSET Rulebook and Guidelines are published by the State Board and are to be followed.
- 1.2.3. If a conflict occurs in interpretation of a rule or guideline, the OHSET Rule Book will be used first, followed by U.S.E.F Inc., O.H.A., W.H.O (Gaming) U.S.D.F. (Dressage) rules.
- 1.2.4. All issues need to be communicated in a timely manner.
- 1.2.5. If concerning a specific class, communicate prior to completion of the class.
- 1.2.6. Other issues shall be communicated prior to completion of the meet.
- 1.2.7. After the new season starts, clarifications will be made public via email, and other appropriate lines of communication including direct communication with the District Chairs and State Board Members.

### 1.3. Rule Updates

- 1.3.1. Will be communicated to Districts.
  - 1.3.1.1. Districts will communicate to the schools.

- 1.4. **New Rules** that are missed during the printing of the rule book will be communicated via email and other lines of communication with District Chairs, State Board Members and Judges.

### 1.5. District Stewardship Committee(s)

- 1.5.1. A Stewardship Committee for District meets will be formed prior to the start of a competition.
- 1.5.2. Decisions will be made by the District Stewardship committee.
  - 1.5.2.1. If the conflict cannot be settled through the use of rule books and a satisfactory

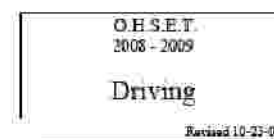
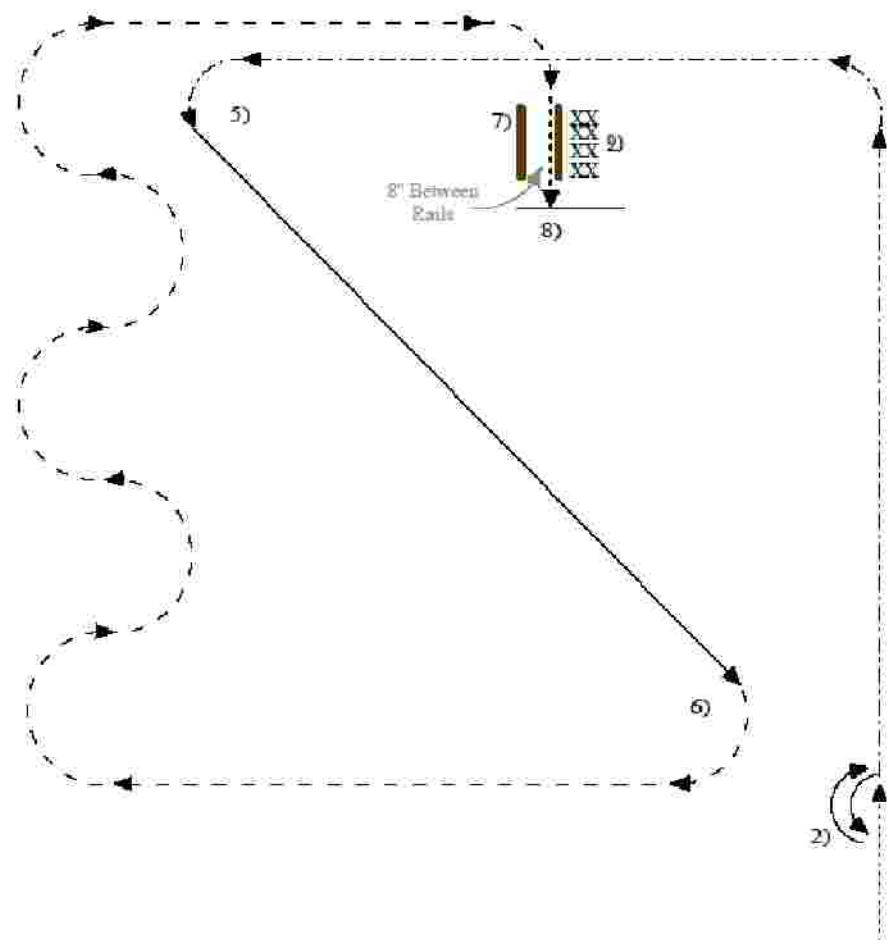

Minimum 8' Off Rail

Legend:	
Wall:	-----
Slow Turn or Jog:	- - - - -
Working Trot:	.....
Strong/Extended:	.....
Test:	.....
Caution:	▲

Date _____ District _____			
<b>CLASS: DRIVING</b>			
HIGH SCHOOL _____	ATHLETE # _____		
<p><b>Expectations:</b></p> <p><b>Walk:</b> A free, flat-footed, regular and unconstrained walk of moderate extension <i>is required</i>. The equine should walk energetically, but calmly, with an even and determined pace.</p> <p><b>Slow Trot/Jog:</b> The equine should maintain impulsion while showing submission to the bit.</p> <p><b>Working Trot:</b> This is a pace between the strong and slow trot. The equine should go forward freely and straight on a rail, but light rein.</p> <p><b>Strong or Extended Trot:</b> This is a clear, but not excessive, increase in pace and lengthening of stride while remaining well balanced. Light contact to be maintained. Excessive speed will be penalized.</p> <p>Grooming and clean gear will be noted and will be considered in the Overall Reinsmanship scoring. The course is set for standard, draft or paint equines. Use and play arena space appropriately. The pivots should be steady continuous motion with little or no movement in the pivot wheel.</p> <p><b>Equipment Needed:</b> 2 - 8"-10" rails (3-6" in diameter)</p>			
#	ELEMENT JUDGED	COMMENTS	SCORE
1.	Walk, one horse's length		
2.	180 degree left wheel pivot		
3.	180 degree right wheel pivot		
4.	Working trot		
5.	Extended trot across diagonal		
6.	Before corner transition to jog: trot - serpentine in jog trot		
7.	Walk through poles - right wheel between poles		
8.	Stop, settle		
9.	Back right wheel completely through, walk forward through poles; stop wait to be excused		
10.	Overall Reinsmanship		

Revised 11.5.08

interpretation cannot be arrived at during the District Level Stewardship Committee meeting; the District Chair will attempt to contact the State Rules Chair or the State Chair to solve the issue.

1.5.2.2. If the requestor is not satisfied by District Stewardship Committee decision the District Chair will send a complete history of the conflict with all sides represented to the State Rules Chair and State Chair. Confidentiality is highly recommended.

1.5.2.3. The State Rules Committee will present recommendation to the State Board for a final decision. An appeal to this decision may be filed with a formal letter and **\$50** sent to the State Board. Petitioner may present appeal. The State Board will review and report back prior to the next meet or as soon as possible.

1.5.2.4. The State Board decision is final.

## 2 Participation

### 2.1 General Participation in OHSET

- 2.1.1 The coaches and advisors forming the equine sport program must follow school, OHSET, and OSAA guidelines.
- 2.1.2 A team must have the approval of the proper authorities of the school as indicated on the Team Registration form.
- 2.1.3 Volunteers, coaches, advisors and team support people must understand and sign in agreement, the OHSET Code of Conduct Standards.
- 2.1.4 Originals of the Code of Conduct and Release form must be filed with the District Secretary and be kept available in the office at each meet.
- 2.1.5 A participation fee, established prior to the competition season, will be charged to each athlete.
- 2.1.6 Fees paid as required by the District prior to participation in any event.
- 2.1.7 **District Rules:** All districts will be required to have a copy of their district rules on file with the State. This will be turned in with their registration. Purpose: Immediate resolutions of issues that concern disbursement of money, code of conduct infractions and they can be used to back up legal inquiries.

- 2.1.8 **New District Chairs** will receive the following information:
1. District Chair Manual
  2. OHSET State Patch
  3. Rule Book
  4. Agreement to attend District Chair trainings and retreats.
- 2.1.9 **New Advisor's / Coaches** will receive the following information when they become part of OHSET:
1. Advisor & Coaches Manual
  2. OHSET State Patch
  3. Rule Book
  4. Coach certification information as required by the school they represent.

2.2 **Team Participation in OHSET**

- 2.2.1 Every Team Advisor and Coach will comply with the rules and guidelines as set forth by their high school in regard to security and or Criminal History Background. Refer to Advisor and Coach Expectations
- 2.2.2 Adult supervision (21 years or older) must be present at all team activities.
- 2.2.3 The teams that are located in the district will participate and be part of that district.
- 2.2.4 A team can consist of both competing and non-competing athletes (grooms). Only Competing Athletes will count toward the team's large, medium, small team designation, refer to Section 100.2.5.
- 2.2.5 **Team Rules:** All teams will be required to submit a copy of their team rules to the district. These will be submitted annually with the registration of each school team. A copy of each school's Code of Conduct will be included with this compliance. **Purpose:** Immediate resolution of issues that concern disbursement of money, code of conduct infractions and they can be used to back up legal inquiries.

**DRILL EXPLANATION SHEET (2009)**  
Circle One  
**Working Fours (4)**      **Short Program (6+)**

TEAM NAME \_\_\_\_\_ Page \_\_\_\_\_

**A. REQUIRED MANEUVERS:**      **B. DRAWN REQUIRED MANEUVERS:**

1. #11 Single file cross	1. #71 Zipper
2. #1 Change of pace (gait)	2. #92 Heart
3. #95 Circle	3. #59 Suicide Charge
4. #5 A maneuver by pairs	4. #15 4-way Box
5. #9 A maneuver by fours	5. #152 45 degree circle through herringbone
6. #35 Single line abreast	6. #106 Circle (roll back to pairs)

\*Note # indicates maneuver number from the drill manual.

**IN ORDER THEY OCCUR, LIST MANEUVERS IN YOUR DRILL**

MANEUVER	A. REQUIRED	B. DRAWN	SET-UP MANEUVER
1			
2			
3			
4			
5			
6			
7			
8			
9			
10			
11			
12			
13			

SHORT PROGRAM DRILL (6 riders or more) - WORKING 4's (trial only)  
SCORE SHEET (2009)

TEAM NAME(S):	Score:	Judges Comments:
<b>REQUIRED MANEUVERS</b>		
1) Single File Cross	10	
2) Change of Pace	10	
3) A Circle	10	
4) A Manoeuvre by Pairs	10	
5) A Manoeuvre by Pairs	10	
6) Single File Ahead	10	
or Emergency Front		
<b>SUB-TOTAL</b>	<b>60</b>	
<b>EXECUTORS OF DRILL</b>		
Alignment/Accuracy	15	
Spacing	15	
Timing/Coordination	15	
<b>GENERAL IMPRESSION</b>		
Performance of the Drill	10	
Cavalry's Horse & Equipment	10	
Dress, Manners & Performance	10	
<b>SUB-TOTAL</b>	<b>25</b>	
<b>DRIVEN REQUIRED MANEUVERS</b>		
1) Zipper (71)	10	
2) Heave (92)	10	
3) Single Charge (59)	10	
4) 4-Way Box (15)	10	
5) 4-Way Box through a ring (52)	10	
6) Circle (roll back to pairs) (106)	10	
<b>SUB-TOTAL</b>	<b>60</b>	
<b>DRILL DESIGN</b>		
Originality/Ingeniousness	15	
Spontaneity/Crowd Appeal	15	
<b>Horsemanship</b>		
		25
<b>SUB-TOTAL</b>	<b>30</b>	
<b>MECHANICAL DEDUCTIONS</b>		
Rider's or Driver's Equipment	100	
Collision No Fall of Horse/ Rider	100	
Excessive uncontrolled speed	100	
Fall of Horse/ Rider	100	
Fall due to Collision	100	
Re-mount	100	
Time (over 10 min) (4 to 6 Min)	100	
<b>SUB-TOTAL</b>	<b>600</b>	
<b>TOTAL SCORES:</b>	<b>1350</b>	<b>GRAND TOTAL:</b>

2.3 Athlete Participation in OHSET

- 2.3.1 **Eligibility:** Any high school student, regardless of race, creed, sex, ability or skill level, physical or mental challenge may participate in OHSET.
- 2.3.2 A student may participate in OHSET for 4 consecutive years or 8 semesters or the equivalent after entering the 9<sup>th</sup> grade.
- 2.3.3 All of the athletes representing a school must be enrolled in and attending that school. Exceptions will be addressed by the State Board and will be consistent with the OSAA rules as much as possible.
- 2.3.4 Students representing a high school shall not compete against unattached individuals. Example: If a meet is scheduled for high schools, everyone competing must represent his/her high school. There can be no unattached individuals entered in any of the events.
- 2.3.5 Each student athlete must supply their own health- accident insurance.
- 2.3.6 Athletes participating in an OHSET associated activity must wear a properly adjusted regulation ASTM/SEI helmet while mounted or in a vehicle (cart, wagon, buggy, etc) being pulled by one or more equines.
- 2.3.7 The student athlete must meet the scholastic requirements and/or the athletic guidelines of OSAA or their school in order to be eligible to participate in OHSET.
- 2.3.8 Athlete's parents/guardians are responsible for athlete transportation and transportation of their Equine.
- 2.3.9 **Code of Conduct Standards and Release:** All athletes and their parents or guardian must read, sign and understand the OHSET Code of Conduct Standards and Release form.
- 2.3.10 **Registration of Athlete:** A completed competitor registration form with listed attachments (below) must be signed, filed with team and available at all events and practices.

- Medical insurance information
- Confirmation of Scholastic Eligibility
- Code of Conduct
- Goal and Evaluation sheet

- Health Release Form
- 2.3.10.1 Completed registration of each athlete will include:

- Paid fees involved in participation
- Rule Book
- OHSET State Patch
- Athlete number
- Opportunity to be elected as a Youth Rep to the State Board (this is important to Athletes College bound).

2.3.11 **Competing Athlete:** Student in 9-12 grade interested in competing on an equestrian team who:

- Has a team advisor/team coach
- Meet their High School criteria for participation in athletic or club activities
- Meet OHSET registration criteria including, but not limited to:
  - Register with the district and the state
  - Total fees paid to state and district
  - Signed OHSET Code of Conduct and Release form
  - Copy of medical insurance card required
  - Scholastic requirements met per school requirements

2.3.11.1 Competing Athletes are entitled to:

- Participate and practice as a rider/handler with team
- Compete as Athlete at District Meets
- Attend and participate in District and State Board meetings
- Qualify and compete as a rider/handler in the State Meet

2007 Training Level Test 3						NO.			
<p>Purpose: To confirm that the horse's muscles are supple and loose and that it moves freely forward in a free and steady rhythm, accepting contact with the bit.</p> <p>All trot work may be ridden sitting or rising, unless stated.</p> <p>Halts may be through the walk.</p> <p>Introduce: Stretching circle at trot, 10m half circle at trot.</p> <p>READER PLEASE NOTE: Anything in parentheses should not be read.</p>						<p>CONDITIONS:</p> <p>Arena: Standard or Small.</p> <p>Average Time: 5:00 (SM) or 4:00 (SMALL)</p> <p>Maximum Possible Points: 250</p>			
						Penalties			
	TEST	DIRECTIONS (DRAS)	POINTS	F	TOTAL	REMARKS			
1	A	Enter working trot	Straightness on centerline, transitions, quality of halt and trot						
	X	Halt, Salute							
	X	Proceed working trot							
2	C	Circle left	Quality of turn at C and E, quality of trot, roundness of circle.						
	E	Turn left							
	X	Circle left 20m							
3	X	Circle right 20m	Quality of trot, roundness of circle, quality of turn at B						
	B	Turn right							
	X	Circle right 70m, developing right lead, canter first quarter of circle							
4	A	(Score for canter)	Caltness and smoothness of depart						
	A	(Score for canter)							
	5	(Score for circle)							
6	B-B	Half circle 20m, near centerline working trot	Quality of canter, trot and bend, balance and smoothness of transition, straightness B to A						
	R	Straight ahead							
	7	Medium walk							
8	X-R	Free walk	Quality of free walk, straightness and transition	1					
	9	Medium walk							
	Y	Working trot							
10	C	Circle left 20m, developing left lead canter first quarter of circle	Caltness and smoothness of depart						
	10	(Score for transition)							
	11	(Score for circle)							
12	B-B	Half circle 20m, near centerline working trot	Quality of canter, trot and bend, balance and smoothness of transition, straightness B to C						
	D	Straight ahead							
	13	Circle left 20m, rising trot, following the horse to stretch forward and downward							
	Before C	Shorten the rein	Quality of stretch over back, forward and downward into a light contact while maintaining balance and quality of trot	2					
	14	Half circle 70m to X							
	X	Straight ahead							
	G	Halt, Salute	Quality of trot, quality and bend of half circle E-X, straightness on centerline, quality of transition and halt						
Leave present: A on walk on a long rein									
COLLECTIVE MARKS:									
GAITS (freedom and regularity)				2					
IMPULSION (elastic to move forward, activity of the seat, suppleness of the back, engagement of the hindquarters)				2					
STIMULATION (balance and confidence, harmony, lightness and ease of movements, acceptance of the bridle, lightness of the forehand)				2					
RIDER (position and seat, correctness and effect of the aids)				5					
<p>REITER REMARKS:</p> <p>Subtotal: _____</p> <p>Errors: (- _____)</p> <p>Total Points: _____ (Max: 250)</p>									



## Donna's Specialties

Custom Embroidery & Screen Printing

**CUSTOM RHINESTONES**

OSU Licensed Supplier  
Team Wear and Supplies  
Letterman Jackets - DC Jeans  
Jackets—Sweats—Hats—Bags  
Specialty Shirts & Hats

---

### **OHSET: POLOS, SWEATS, T'S**

---

**HYALUN**  
Joint Care for Horses

**Tahitian Noni**  
Equine Essentials

**TIPPMAN SPORTS**  
(Paintball Markers and Accessories)

**Donna N. Espelien**

Ph: 503-543-2519 or Cell: 503-806-2781

Fax: 503-543-3042

32744 Gilmore Rd. - Scappoose, OR 97056

Email: ardonnas@centurytel.net

[www.companycasuals.com/DonnaSpecialties](http://www.companycasuals.com/DonnaSpecialties)

2.3.12 **Non Competing Athlete:** Student in 9-12 grade interested in participating on an equestrian team who:

- Receive Year End District and State Meets Awards
- Has an advisor/team coach
- Meet their High School criteria for participation in athletic or club activities
- Meet OHSET registration criteria including, but not limited to:
  - Register with district and state
  - Total fees paid to state and district
  - Signed OHSET Code of Conduct and Release Form
  - Copy of medical insurance card required
  - Scholastic requirements met per school requirements

2.3.12.1 Non-Competing Athletes are entitled to:

- Participate during OHSET practices, functions, and meets
- Non Competing Athletes participation may include, but is not limited to:
  - Groom
  - Team Manager
  - Team Secretary
  - Team Treasurer
  - Stall Cleaner

## 2.4 Athlete Uniform

2.4.1 **Helmet:** All athletes participating in an OHSET sponsored riding or (equine drawn) driving activity, **MUST** wear an ASTM/SEI Helmet, properly adjusted according to manufacturer's instructions.

2.4.1.1 The helmet must maintain the proper adjustment throughout the entire event or a disqualification may occur.

- 2.4.1.2 No Decorated (adornments of any kind) helmets allowed.
- 2.4.1.2.1 **Exception.** Helmet Covers: Solid or Multi-Colored helmet covers are allowed in all events.
- 2.4.2 **Polo Shirt:** Upon entering the arena for a class the athlete must wear a solid colored polo shirt with collar, long sleeve rolled down to the wrist, and shirt tucked in is part of the required uniform.
- 2.4.2.1 One solid color, long sleeve polo shirt may contain:
- Athletes' number
  - Athletes' name
  - School name, clearly visible on shirt
  - School Logo
  - One American flag 2" x 3"
  - Sponsor logo not to exceed 2 square inches
- 2.4.3 **Safety Vest:** A safety vest may be worn by any athlete in any event. Safety vest may be worn under or over the polo shirt as long as the athlete's number is clearly visible.
- 2.4.4 **Pants:** Western style pants or jeans of solid color, Breeches or Jodhpurs of solid color.
- 2.4.4.1 Pants must be proper style for class discipline. (Western for Western style of riding, breeches or jodhpurs for English Style of riding).
- 2.4.4.2 Saddle Seat Pants may have pin stripes
- 2.4.5 **Boots:** Must be appropriately corresponding boots for the style of riding and tack used.
- 2.4.6 **Miscellaneous**
- 2.4.6.1 No adornments are allowed (pinned, sewn, glued, or otherwise artificially attached) on uniform.
- 2.4.6.2 Athletes with long hair need to wear it neatly, so number is clearly visible.

## District Chairs 2008-2009

<p><b>Central</b>            Karen Friend  <a href="mailto:friends@outlawnet.com">friends@outlawnet.com</a>            541 923-2119            68307 George Cyrus Road            Sisters, OR 97759</p>	<p><b>North East</b>            Chris Dinsmore  <a href="mailto:dinsmore_chris@yahoo.com">dinsmore_chris@yahoo.com</a>            H 503-678-6595            503-678-6652 fax            20781 Olmstead Rd NE            Aurora, OR 97002</p>
<p><b>North Valley</b>            Karissa Dishon  <a href="mailto:karissadishon@yahoo.com">karissadishon@yahoo.com</a>            503-266-4012            940 S. Fir Ct            Canby, OR 97013</p>	<p><b>North West</b>            Donna Espelien  <a href="mailto:ardonnas@centurytel.net">ardonnas@centurytel.net</a>            H-503-543-2519            Fax-503-543-3042            32744 Gilmore Rd            Scappoose, OR 97056</p>
<p><b>South Valley</b>            Debbi Langeliers  <a href="mailto:svdistrictchair@yahoo.com">svdistrictchair@yahoo.com</a>            541-726-9291            4660 Main St., STE 400-2            Springfield, OR 97478</p>	<p><b>Southern</b>            Jim Roper  <a href="mailto:roperjs@surfpower.net">roperjs@surfpower.net</a>  <a href="mailto:jroper@or.blm.gov">jroper@or.blm.gov</a>            541-476-8177            541-471-6631-work            541-471-2907-fax            333 Countyaire Dr.            Grants Pass, OR 97526</p>
<p><b>Tri-River Valley</b>            Todd Gary  <a href="mailto:garyt@molalla.net">garyt@molalla.net</a>            503-829-8506</p>	<p><b>Willamette</b>            Pam Miller  <a href="mailto:Rmiller0809@comcast.net">Rmiller0809@comcast.net</a>            503-581-1445            3739 Shadow Lane SE            Salem, OR 97301</p>

## Committee Chairs 2008-2009

<b>Registrar</b> <b>Chris Dinsmore,</b> <a href="mailto:Dinsmore_chris@yahoo.com">Dinsmore_chris@yahoo.com</a> , 503-678-6595 503-678-6652 fax, 20781 Olmstead Rd NE Aurora, OR 97002	<b>Points Chair</b> Karen Friend <a href="mailto:friends@outlawnet.com">friends@outlawnet.com</a> , (541) 923-2119, 68307 George Cyrus Road Sisters, OR 97759
<b>Rules Co-Chair</b> Karen Bragg, <a href="mailto:KBragg@paintedvalley.com">KBragg@paintedvalley.com</a> , 503-887-7275 503-682-4982 fax, 25100 SW Garden Acres Rd Sherwood, OR 97140	<b>Rules Co-Chair</b> Katie Stodick, KStodick@paintedvalley.com, 503-678-6530, 132-118 Donald Rd Aurora, OR 97002
<b>Scholarship &amp; Insurance</b> <b>Linda Crawford</b> <a href="mailto:forthay@frontiernet.net">forthay@frontiernet.net</a> , <b>541-597-2899</b> , PO Box 508 Selma, OR 97538	<b>Judges Chair</b> JoAnn Oswald, , <a href="mailto:Oswald99@yahoo.com">Oswald99@yahoo.com</a> , 503-623-6559, 16770 Ellendale Ave Dallas, OR 97338
<b>Co-Ops</b> Bill Weir <a href="mailto:BillWeir@aol.com">BillWeir@aol.com</a> , 541-935-4666 87593 Miller Rd Veneta, OR 97487	<b>Awards</b> Karissa Dishon, <a href="mailto:karissadishon@yahoo.com">karissadishon@yahoo.com</a> 503-266-4012 940 S. Fir Ct. Canby, OR 97013

### 2.5 Tack & Equipment

2.5.1 If a Judge deems required equipment is not present, athlete may not continue on the course.

### 2.6 Athlete Participation in Meet

2.6.1 Points for events in all 3 meets will be added together.

2.6.2 Athlete/Team competes in two (2) of three (3) meets to qualify for State Championship.

2.6.3 Athlete/Team competes in a class, two of three meets to qualify for that class at State Championship.

2.6.3.1 Current Season record breakers must participate, in the event they broke the record in, at least 2 out of 3 meets.

2.6.4 An athlete may participate in up to five (5) individual classes, and all team events. Athletes may only ride in each individual or team event one time per meet.

2.6.4.1 Athletes from a school participating in a Team Event must be of the same discipline including the same color shirt for uniformity.  
 Example: IHOR class all members of Team A: will be all English or all Western style (not 3 English and 1 Western).

2.6.5 Athletes will wear assigned number in the arena while participating.

2.6.6 Varsity/Junior                      Varsity                      Participation



## Western Horsemen of Oregon

**Our Goal is to promote pattern horse racing among the men and women of the State of Oregon**

[President@westernhorsemenoforegon.com](mailto:President@westernhorsemenoforegon.com)  
<http://westernhorsemenoforegon.com/>

**Board of Directors 2008-2009**

- 2.6.6.1 Each team will have a total of fifty-one (51) Varsity slots and one hundred and two (102) Junior Varsity slots to be utilized in their individual events.
- 2.6.6.2 Junior Varsity Athletes may ride in the competition as the schedule allows.
- 2.6.6.3 Individual Junior Varsity points are not awarded to the Team. (see Scoring/Placing)
- 2.6.6.4 At the advisor/coach’s discretion, a Junior Varsity member may ride as a Varsity and or Junior Varsity at the same meet as long as there are only 51 Varsity slots used.
- 2.6.6.5 It is up to the advisor/coach of the team as to who will perform in the 51 Varsity/102 Junior Varsity slots.

**2.7 Alternate Participation in OHSET**

- 2.7.1 One (1) alternate will be allowed for three (3) and four (4) person team classes. Two (2) person team classes are not allowed the use of alternates.
- 2.7.2 A new team is formed when anyone other than the original athletes, including their designated alternate, ride in that event.
- 2.7.3 A pool of alternates will be named for teams in each qualifying event prior to the first competition.
  - 2.7.3.1 Once an athlete is drawn from the pool of alternates and rides on a team, he/she becomes a permanent member of that team and that team can use no other alternates.
- 2.7.4 In case of injury or illness, if a team in team events has no alternates, the team may ride short if they have a physician’s written statement or a stewardship committee’s approval.
- 2.7.5 Alternates must be declared prior to participation in a state meet.

**2.8 Equine Participation in OHSET**

- 2.8.1 The team advisor/coach must be informed of any health issues that would affect the participation of the equine athlete.
  - 2.8.1.1 **Equine requiring any medication** will be identified upon arrival at any OHSET event. Athletes are to inform and communicate the need for such medication to their team coach/advisor including a veterinary

<p><b>State Chair</b>                  Candi Bothum  <a href="mailto:Candi.Bothum@oregonstate.edu">Candi.Bothum@oregonstate.edu</a>                  541-548-0573                  PO Box 967                  Redmond, OR 97756</p>	<p><b>Vice Chair</b>                  Karissa Dishon  <a href="mailto:karissadishon@yahoo.com">karissadishon@yahoo.com</a>                  503-266-4012                  Canby, OR 97013</p>
<p><b>Secretary</b>                  Debi Ferrer  <a href="mailto:debi@gorge.net">debi@gorge.net</a>                  541-298-4280                  7152 Mill Creek Rd                  The Dalles, OR 97058</p>	<p><b>Treasurer</b>                  Karren Cholewinski  <a href="mailto:kkcholewinski@msn.com">kkcholewinski@msn.com</a>                  541-343-6650                  90707 Funke Rd                  Eugene, OR 97408</p>

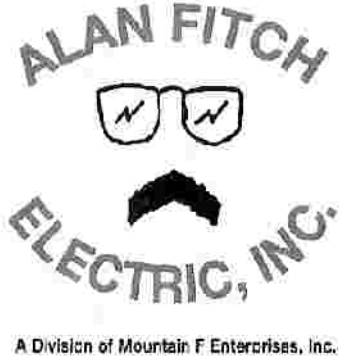

**ELECTRICAL CONTRACTOR**

- COMMERCIAL
- RESIDENTIAL
- INDUSTRIAL

**OFFICE: (503) 632-4784**  
**CELL: (503) 313-0761**  
**FAX: (503) 632-5521**

ELEC. BUS. LIC. # 3-387C  
 CCB # 151952

**25973 S. MOEHNKE LN.**  
**BEAVERCREEK, OR 97004**

to an equine if the person, prior to assisting the veterinarian or farrier, executes a release stating that the person rendering assistance waives the right to bring an action against the veterinarian or farrier for any injury or death arising out of assisting in the provision of veterinarian or farrier services. A release so executed shall be forcible regardless of lack of consideration.

(2) A release executed pursuant to this section shall not limit the liability of a veterinarian or farrier for gross negligence or intentional misconduct.

30.697. Effect on workers' compensation benefits.

Nothing in ORS 30.687 to 30.695 shall affect the right of any person to any workers' compensation benefits that may be payable by reason of death, injury or other loss.

HISTORY: 1991 c.864 @ 6



Alan & Beth Fitch  
(503) 632-4784

25973 S. Moehnke Lane  
Beavercreek, OR 97004

prescription, prior to competing at current District or State Meet. Obvious lameness or unsoundness detected in participating horses can/will result in disqualification, the only exception to this statement and rule is: Equine must have written veterinary permission to perform and includes the statement "will not further the injury or cause increased pain."

2.8.1.2 **Drugging horses/lameness:** The OHSET Organization and its Board members do not condone the use of drugs, herbal compounds, or surgical procedures which affect an animal's conformation, appearance, or natural performance.

## 2.8.2 **Cruelty**

2.8.2.1 If cruelty is reported, it will be investigated and appropriate action taken. If persistent, it will be reason for elimination or disqualification from that meet.

2.8.2.2 Refer to Code of Conduct violation procedure for appropriate action.

2.8.3 Equines cannot be shared in the same class in a single meet.

2.8.3.1 Equine may be used in the same class from district to district. If more than one athlete qualifies for state with that equine, only ONE athlete will be able to use it (per event) at the State Championship.

2.8.3.2 An equine used for In-Hand Trail cannot be cross-entered as a riding animal by anyone at any OHSET competition during the same season.

2.8.3.2.1 This equine MAY be used in Driving, In Hand Obstacle Relay and Showmanship.

## 2.8.4 **Equine Age:**

2.8.4.1 The age of the equine is stated as of January 1st of the birth year. Example: A equine born May 4<sup>th</sup> 2007 would turn 1 year old on January 1<sup>st</sup> 2008

2.8.4.2 Equine 5 and under in any western class may use a regulation snaffle or rawhide bosal.

2.8.4.3 Equine 6 and over may use any standard bit for that class or breed (except timed events, working pairs and drill.) Refer to specific class rules for further clarification.

**2.8.5 Miniature Equine:**

2.8.5.1 Definition of miniature equine: A miniature equine will be determined by the measurement of 38 inches from base of the last mane hair to the ground.

2.8.5.2 **Stallions:** No stallions of any age will be allowed to participate in OHSET.

**3 The Season & Scheduling**

3.1 **OHSET Season** begins December 1<sup>st</sup> of the current school year and ends after State, Regional, or National Competition.

3.2 **No equine practices** shall occur prior to December 1<sup>st</sup> of the current school year or after State, Regional, or National Competition

3.2.1 Team practices and coaching must occur **ONLY** during the scheduled season. This includes:

3.2.1.1 Varsity/Junior Varsity Tryouts.

3.2.1.2 Selection of Events

3.2.1.3 Athletes practicing on foot a specified event. i.e.: drill

3.2.2 OHSET Members may gather at anytime without equine.

3.3 Clinics or other equine related functions may be held outside the scheduled season provided they are open to all schools. Clinic organizers must notify the State Board prior to the clinic to communicate with all districts and obtain appropriate OHSET insurance.

3.4 Each district will hold three competitions between the General Meeting and three weeks prior to the State Championship.

3.4.1 If possible, the competitions should be held at a facility large enough to accommodate all of the classes in one weekend.

3.4.2 If it is not possible to hold all the events on the same weekend, events should be scheduled as close as possible.

3.4.3 Schools may field as many event teams as they can.

3.4.3.1 Districts may limit event teams if needed.

(b) Nothing in subsection (1) of this section shall limit the liability of an equine activity sponsor or an equine professional:

(A) If the equine activity sponsor or the equine professional commits an act or omission that constitutes willful or wanton disregard for the safety of the participant and that act or omission caused the injury;

(B) If the equine activity sponsor or the equine professional intentionally injures the participant;

(C) Under the products liability provisions of ORS 30.900 to 30.920; or (D) Under ORS 30.820 or 608.015.

30.693. Additional exceptions to limitations on liability; effect of written release.

(1) Except as provided in subsection (2) of this section, nothing in ORS 30.691 shall limit the liability of an equine activity sponsor or an equine professional if the equine activity sponsor or the equine professional:

(a) Provided the equipment or tack, failed to make reasonable and prudent inspection of the equipment or tack, and that failure was a cause of the injury to the participant;

(b) Provided the equine and failed to make reasonable and prudent efforts to determine the ability of the participant to safely ride, train, drive, groom or ride as a passenger upon an equine, to determine the ability of the equine to behave safely with the participant and to determine the ability of the participant to safely manage the particular equine; or

(c) Owns, leases, rents or otherwise is in lawful possession and control of the land or facilities upon which the participant sustained injuries because of a dangerous latent condition which was known to or should have been known to the equine activity sponsor or the equine professional and for which warning signs have not been conspicuously posted.

(2) The limitations on liability provided in ORS 30.691 shall not apply to an adult participant in the circumstances listed in subsection (1)(b) of this section if the participant, prior to riding, training, driving, grooming or riding as a passenger upon an equine, knowingly executes a release stating that as a condition of participation, the participant waives the right to bring an action against the equine professional or equine activity sponsor for any injury or death arising out of riding, training, driving, grooming or riding as a passenger upon the equine. A release so executed shall be binding upon the adult participant, and no equine professional or equine activity sponsor shall be liable in the circumstances described in subsection (1) (b) of this section except as provided in ORS 30.691 (2). 30.695. Effect of written release on liability of veterinarian or farrier.

(1) No veterinarian or farrier shall be liable to any person who assists the veterinarian or farrier in rendering veterinarian or farrier services

for an equine activity, including but not limited to pony clubs, 4-H clubs, hunt clubs, riding clubs, school and college sponsored classes and programs, therapeutic riding programs and operators, instructors, and promoters of equine facilities, including but not limited to stables, clubhouses, pony ride strings, fairs and arenas at which the activity is held.

(4) "Equine professional" means a person engaged for compensation:

(a) In instructing a participant or renting to a participant an equine for the purpose of riding, training, driving, grooming or being a passenger upon the equine; or

(b) In renting equipment or tack to a participant.

(5) "Participant" means any person, whether amateur or professional, who directly engages in an equine activity, whether or not a fee is paid to participate in the equine activity. "Participant" does not include a spectator at an equine activity or a person who participates in the equine activity but does not ride, train, drive, groom or ride as a passenger upon an equine.

**30.689. Policy.**

(1) It is the purpose of ORS 30.687 to 30.697 to assist courts and juries to define the circumstances under which those persons responsible for equines may and may not be liable for damages to other persons harmed in the course of equine activities.

(2) It is the policy of the State of Oregon that no person shall be liable for damages sustained by another solely as a result of risks inherent in equine activity, in so far as those risks are, or should be, reasonably obvious, expected or necessary to the person injured.

(3) It is the policy of the State of Oregon that persons responsible for equines, or responsible for the safety of those persons engaged in equine activities, who are negligent and cause foreseeable injury to a person engaged in those activities, bear responsibility for that injury in accordance with other applicable law.

30.691. Limitations on liability; exceptions.

(1) Except as provided in subsection (2) of this section and in ORS 30.693, an equine activity sponsor or an equine professional shall not be liable for an injury to or the death of a participant arising out of riding, training, driving, grooming or riding as a passenger upon an equine and, except as provided in subsection (2) of this section and ORS 30.693, no participant or participant's representative may maintain an action against or recover from an equine activity sponsor or an equine professional for an injury to or the death of a participant arising out of riding, training, driving, grooming or riding as a passenger upon an equine.

(2)(a) The provisions of ORS 30.687 to 30.697 do not apply to any injury or death arising out of a race as defined in OR 10.

**3.5 Meet Participation**

3.5.1 Meet time slots may be given to schools, not individuals.

3.5.2 If an athlete is not available at the designated team time, that individual's ride may be forfeited.

3.5.3 Drill team order shall be selected by a draw.

**4 Patterns**

4.1 The OHSET State Judges' committee will draw up and submit the patterns for approval by the State Board for each competition year.

4.2 The same patterns will be used at District and State Competitions.

4.3 Pattern classes will be judged on a 1 to 10 basis for each maneuver, 5 being average. A score sheet will be designed for each pattern. See Table Below.

10 points	Excellent	Perfect; no improvement possible (rarely given)
9 points	Very good	Movement hard to fault, but not quite perfect (rarely given)
8 points	Good	Outstanding; lovely to watch (occasionally given)
7 points	Fairly good	Performed nicely, movement above average
6 points	Satisfactory	Movement correct
5 points	Sufficient	Okay, neither good or bad, noncommittal score
4 points	Insufficient	Performed but lacking in precision and/or control
3 points	Fairly bad	No precision, little control or response
2 points	Bad	No response to aids
1 point	Very bad	No control
0 points	Not performed	Rarely given

5 **Judging:**

5.1 OHSET carded judges shall be considered before all others followed by 4-H, WHO, USDF, OHA, USEF and other state and/or National Associations deemed appropriate by OHSET

5.1.1 In the event of an emergency situation or cancellation by the OHSET senior judge, our apprentice judges may be used in the events which they qualify

5.1.1.1 If there are no senior or apprentice judges available, judges other than OHSET qualified, may be used.

5.1.1.2 If an OHSET judge cancels at the last moment, it is the District's responsibility to report the incident to the Judges Committee Chair and the State Chair.

5.1.1.3 OHSET judges will be managed and administered by a Judge's Chair with support and contributions from his/her committee (3 or more chosen by the judge's chair), the State Chair, and/or the current actively participating judges.

5.1.1.4 The committee reports to the State Board.

## Appendix

### EQUINE INHERENT RISK LAW

**The OREGON HIGH SCHOOL EQUESTRIAN TEAMS, INC. program is a school related equine activity. Therefore, all activities are subject to the Oregon State EQUINE INHERENT RISK LAW. ORS 30.687~30.697**  
**By your presence at these activities you have indicated that you have accepted the limits of liability resulting from inherent risks of Equine Activities.**  
**All persons associated with OHSET will be regarded as participants and are limited by the inherent risk law.**

#### Equine Activity Statute State of Oregon

OREGON REVISED STATUTES TITLE 3. REMEDIES AND SPECIAL ACTIONS AND PROCEEDINGS CHAPTER 30. ACTIONS AND SUITS IN PARTICULAR CASES ACTIONS ARISING OUT OF EQUINE ACTIVITIES ORS s 30.687 (1993) 30.687.

Definitions for ORS 30.687 to 30.697.

For the purposes of ORS 30.687 to 30.697:

- (1) "Equine" means a horse, pony, mule, donkey or hinny.
- (2) "Equine activity" means:
  - (a) Equine shows, fairs, competitions, performances or parades that involve any or all breeds of equines and any of the equine disciplines including, but not limited to, dressage, hunter and jumper horse shows, grand prix jumping, three-day events, combined training, rodeos, driving, pulling, cutting, polo, steeple chasing, endurance trail riding and western games and hunting;
  - (b) Equine training, grooming and teaching activities;
  - (c) Boarding equines;
  - (d) Riding, inspecting or evaluating an equine belonging to another whether or not the owner has received some monetary consideration or other thing of value for the use of the equine or is permitting a prospective purchaser of the equine to ride, inspect or evaluate the equine; and
  - (e) Rides, trips, hunts or other equine activities of any type however informal or impromptu that are sponsored by an equine activity sponsor.
- (3) "Equine activity sponsor" means an individual, group or club, partnership or corporation, whether or not the sponsor is operating for profit or nonprofit, that sponsors, organizes or provides the facilities

**Have a Great Season, OHSET Athletes!**

*~ Go Team Barlow ~*





**MARCIA NOLTING**  
**~ Broker**  
**503-704-7333**

**"Here for all your Real Estate Needs...call today!"**

**205 Corporate Center**  
**12901 SE 97th Avenue Suite 220**  
**Clackamas, Oregon 97015**

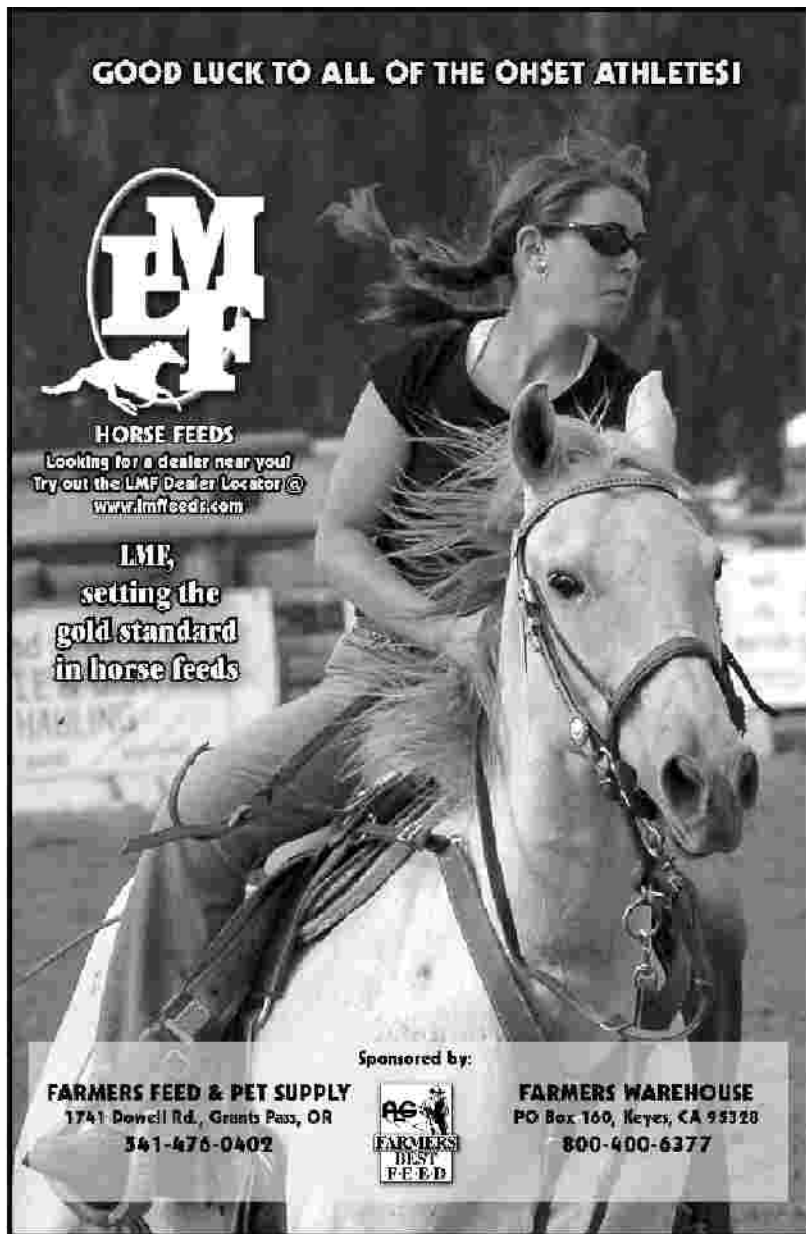
**GOOD LUCK TO ALL OF THE OHSET ATHLETES!**





**HORSE FEEDS**  
Looking for a dealer near you?  
Try out the LMF Dealer Locator @  
[www.lmf8822.com](http://www.lmf8822.com)

**LMF,**  
setting the  
gold standard  
in horse feeds

Sponsored by:

<p><b>FARMERS FEED &amp; PET SUPPLY</b> 1741 Dowell Rd., Grants Pass, OR 541-476-0402</p>		<p><b>FARMERS WAREHOUSE</b> PO Box 160, Keyes, CA 95328 800-400-6377</p>
---	---	--

- 5.1.1.4 The committee reports to the State Board.
- 5.2. Qualifications to obtain an OHSET Judge's Card**
- 5.1.2 Experienced Judges carded in other organizations within the same discipline, including WHO, 4-H, OHA, ODF, USEF, etc. may apply to be an OHSET judge without following the apprentice guidelines.
- 5.1.3 In order for these applicants to be approved, they must:
- 5.1.3.1 Submit an up to date resume' including a minimum of 5 professional, judging related, references and permission to contact references.
  - 5.1.3.2 Attend a meet and scribe for several events, or help set up timed events, etc. (depending on what you intend on judging)
  - 5.1.3.3 Attend an appropriate OHSET Judges' training
  - 5.1.3.4 Take the current OHSET test(s) and receive a 90% or higher score.
  - 5.1.3.5 Receive approval from the judges committee.
- 5.2 Apprentice Judges Guidelines**
- 5.2.1 Must be 20 years of age at application
  - 5.2.2 Must attend a minimum of every other OHSET Judges' Training.
  - 5.2.3 Pass an annual test(s) with a 90% or higher score.
  - 5.2.4 Before entering the apprentice program, scribing for senior judges, or setting timed event courses (depending on disciplines you wish to judge) in the desired classes would greatly increase the understanding of the OHSET program.
  - 5.2.5 Shall apprentice for at least one year (minimum 3 meets) and receive positive evaluations from 3 different judges, at 3 different meets in ALL disciplines you expect to judge. (Apprentice evaluation forms are available on the website)
    - The apprentice judges in the same arena with an OHSET judge
    - She/he scores his/her own sheets (a different color than the senior

**Thanks!**

The Lake Oswego High School Equestrian Team is honored to have the support of these wonderful businesses & organizations!



**THE LAKER CLUB**



**AJ's** Stafford Feed & Pet Supplies  
503-673-0114  
Specializing in horse care products, joint supplements, vitamins and feed.



**BLUE SAGE CAFE**  
American Favorites with a Southwestern Flair  
www.bluesagecafe.com



**JOKER'S TREATS**  
Quality Horse Care



**KRAFT**



**Julie's Travel Desk**  
juliestravel.com



**HALT**<sup>®</sup>  
PEST  
**CONTROL, INC.**  
(503)524-8548 or 1-800-GOT-BUGS  
*"Bring your pest control problems to a Halt"*

appropriate channels to the State Championship or District Stewardship Committee.

32. **Dispute Resolution/Stewardship**  
32.1. All disputes will be resolved as described in the OHSET District Meet/State Championship STEWARDSHIP PROCESS Guidelines.
33. **Code of Conduct**  
33.1. All athletes, volunteers (coaches/advisors, parents) and persons contracted with (Judges, Timers, and Stock Contractors) OHSET during an OHSET competition shall comply with the OHSET Code of Conduct Standards.  
33.2. Any violation of the standards contained therein will lead to a confidential investigation and appropriate disciplinary actions.
34. **State Stalls**  
34.1. No refund will be given once stall(s) have been reserved.
35. **Camp Sites**  
35.1. No refund will be given once camp sites have been reserved.

## **MyOregonHorseForSale.com**

-----  
Equine Events ~ Horses for Sale ~ Video Ads  
Slideshow Ads ~ Stallions at Stud ~ All Breeds

**ALL OREGON**

-----  
**Contact Bonnie Davee at 541-788-0444**  
**Or email: [Oregon@myhorseforsale.com](mailto:Oregon@myhorseforsale.com)**



30.5.1.3. Any dispute on arena setup by Coaches/Advisors will be addressed in accordance with the OHSET Communication Expectations section prior to this certification  
ARENA ARRANGEMENT

### 30.6. Judging at State Championships,

30.6.1. **Performance Classes** will be double judged (2 Judges),

30.6.2. **Drill Classes** will be quad judged (4 Judges)

30.6.3. **Timed Events** will be judged, timed and electronically recorded.

#### Clarification:

State Qualifiers/Alternates

When an Athlete /Team qualify only as a DM/DR, they are always in addition to the normal allotment for that class – over and above the amount based on medalist and/or the 10% rule. Initially, our alternate process works as usual, ignoring the DM/DR qualifier.

However, that **DM/DR** qualifier also sits at a season point total that would have listed them as some level of alternate (1<sup>st</sup>, 2<sup>nd</sup>, tied for 3<sup>rd</sup>, 4<sup>th</sup>, etc.). Our alternate-pulling-in-process works as usual, ignoring the DM/DR qualifier, until you reach the point total level in that class for the DM/DR qualifier. At that point, the DM/DR qualifier then fills the qualifier spot according to their alternate status, and the class is back to sending their normal allotment, based on medalist, and the 10% rule.

**So, the DM/DR qualifiers are above the normal allotment only until they qualify anyway as an alternate. Then back to the standard alternate process, with them filling an alternate spot based on their season point total**

### 31. Communications

31.1. The basic communication flow within OHSET is outlined in the Communications & Expectations section of the Rulebook. This same communication flow will be in place for the State Championship. During the Timed (Gaming) and Cattle events at the State Championship, Gate Stewards will be easily identified by wearing Orange Vests. These volunteers will be the point of contact to check into the event and determine a competitor's order of go. Any dispute/protest will not be registered with the Gate Steward. Dispute/protest will be registered with the appropriate Team Advisor/Coach and forwarded through the

judge) and makes notations as if judging the class on his/her own

- The apprentice will meet, compare, and discuss their judging with the official OHSET judge at the end of the competition, or at convenient times throughout the show (do NOT slow the schedule)

- Both the official judge and the show management will fill out and submit an evaluation form for the apprentice judge and mail to the Judge's Committee Chair.

5.2.6 Once 3 positive evaluations, from 3 different meets, from 3 different official OHSET judges, are received, the apprentice judge will be reviewed for official status in the appropriate experienced categories.

5.2.6.1 The apprentice may request from the judges committee the results of his/her evaluation at any time and will be notified when the criteria have been met.

5.2.7 Apprentices will be carded only in the disciplines they have successfully judged

5.2.8 Evaluation and final decision, concerning carding, remains with the Judges' Committee

5.2.9 An apprentice judge is identified by an "A" on the back of his/her judge's card.

5.3 **In order to retain a judge's card in OHSET**, judges will be required to:

5.3.1 Attend a minimum of every other OHSET Judge's Training or another pre approved (by the Judges Committee) clinic that offers OHSET specific training.

5.3.2 Receive a majority of positive evaluations

5.3.3 Remain actively judging in OHSET and/or other organizations; a minimum of 1 OHSET show in the previous 2 years.

5.3.4 Pass an annual, open book, exam with a score of 90% or higher.

5.3.4.1 **Timed event judges** will be required to take a closed book test demonstrating their knowledge of course set up.

#### 5.4 **Conduct of OHSET Judges**

- 5.4.1 A judge will only be allowed to officiate in the divisions they have qualified in and should let the competition committee know of any areas qualification is lacking
- 5.4.2 Judges will be deemed qualified only in areas they can demonstrate knowledge, previous judging experience or apprentice and receive positive evaluations of.
- 5.4.3 An OHSET Judge's Card is valid for two years.
- 5.5 Any exceptions to the rules for remaining on the list, apprenticing, or becoming an OHSET judge, (only in extreme circumstances) must be approved by a majority vote of the judges' committee.
- 5.6 Each year the Judges' Committee will re-evaluate the standards and procedures of the committee function in regard to judge qualification and carding. The State Board will approve any changes. This will ensure the continued quality of the OHSET goals in this area.
- 5.7 All correspondence regarding judges should be directed to the current Judges' Chair
- 5.8 Contracting Judges
  - 5.8.1 When hiring a judge, the contract should be sent within 2 weeks of contact and should include:
    - 5.8.1.1 Exact events to judge
    - 5.8.1.2 Lodging Agreement
    - 5.8.1.3 Exact Pay, including overtime if available
    - 5.8.1.4 Estimated hours expected to judge
    - 5.8.1.5 What amount is included for meal and mileage reimbursement
- 5.9 **District Judges Evaluation Forms** should be submitted from each district to the Judges Committee based on observations and comments on each judge used at OHSET competitions. These evaluations will serve as a resource for future clinics and constructive improvement for current card holding judges. District Judges Evaluation Forms are available on the OHSET website.

- 30.3.3. Only registered OHSET athletes may ride at the State Championship
  - 30.3.4. Other State Championship Qualifications
    - 30.3.4.1. Qualification of District and State Record holding athletes must break record in an OHSET recognized timed event. (DR)
    - 30.3.4.2. Athlete must break record for the current season.
    - 30.3.4.3. If a record is not broken, previous year('s) record holder does not automatically qualify.
    - 30.3.4.4. Must break record for the current season, and hold that record at season's end.
      - 30.3.4.4.1. Athlete/Team competes in a class, two of the three meets to qualify for that class at State Championship.
  - 30.3.5. Athletes placing 1<sup>st</sup>, 2<sup>nd</sup> or 3<sup>rd</sup> in 2 meets, (DM) in the same event qualify for the State Championship.
  - 30.3.6. 10% of average event size qualifies for State Championship (includes award winners).
  - 30.3.7. To qualify for state, competitors must have earned points other than participation points in that class during the season.
  - 30.3.8. Districts will only name three alternates as state qualifiers in each class.
- 30.4. **Proof of age of equine** will be required at State Championship for any equine 5 and under.
- 30.5. **Team Penning.**
- 30.5.1. At the **state meet** the host district will furnish the pen for this event.
    - 30.5.1.1. Upon notification by set-up crew, the Chair of the Judges Committee and the event judges will "walk" the arena to ensure the footing is safe, barrier/timing equipment is still functional and event equipment is correctly positioned.
      - 30.5.1.1.1. Coaches/Advisors may view the set-up from the sideline, but will not be allowed in the arena during the walk through.
      - 30.5.1.1.2. Once satisfied the arena is correctly set up, the Chair of the Judges Committee will "certify" that arena for competition and the event will begin.
    - 30.5.1.2. After the arena is certified, the event will proceed with the arena "as is".

## State Meet

### 30.1. State Stewardship Committee

- 30.1.1. The State stewardship committee will consist of the State Chair, State Event Coordinator, State Rules Chairperson, State Judges Chairperson and one (1) District representative from each of the respective districts with a minimum of 5 districts.
- 30.1.2. The state meet will continue on schedule while stewardship meetings are being held.
- 30.1.3. Only State meet officials may set up practice obstacles in practice areas at the state meet.
- 30.1.4. Final decisions will be made by the State Stewardship committee.
- 30.1.5. All procedures are as they are outlined in Section 1...Rule Interpretation

### 30.2. State Awards

- 30.2.1. Awards are given at the end of the State Championship Meet.
- 30.2.2. Gold, silver and bronze medals are awarded for the top three places in all events.
- 30.2.3. All members of a Team receive individual awards for that team event.
- 30.2.4. All Gold Medal Teams will receive a team award
  - 30.2.4.1. Other Awards
    - Sportsmanship award at State meet will be selected and awarded to a District
    - High Point Large Team 16 and over (competing athletes)
    - High Point Medium Teams 8-15(competing athletes)
    - High Point Small Team 1- 7 and under (competing athletes)
    - Team Size will be determined by the number of registered Competing Athletes on the team roster at the final registration date.
    - Timed event
    - Performance
    - Scholarship

### 30.3. State Championship Qualifications

- 30.3.1. State Championship qualifying athletes will be determined by year end point totals at the District level.
- 30.3.2. All medal winners qualify for State Championship.

## 6. Cooperative Sponsorship

- 6.1. The OHSET rules regarding Cooperative Sponsorship of equestrian teams will use as a guideline the rules as set forth by the Oregon School Activities Association (OSAA).
  - 6.1.1. Each application for Cooperative Sponsorship will be evaluated and voted upon based on individual merit.
  - 6.1.2. Exceptions to OHSET's cooperative sponsorship process may be made due to specific circumstances. In no case shall an exception granted be deemed a precedent on which to base future decisions regarding cooperative sponsorship.
  - 6.1.3. Only Schools, Districts, or State organizations may apply for cooperative sponsorship, not families or individuals.
  - 6.1.4. Recruitment of athletes, and any conduct or circumstances toward that end, or to the appearance thereof, is to be strongly discouraged; and any application presented with that intent will be denied.
  - 6.1.5. Geographic proximity requirement
    - 6.1.5.1. Applying schools requesting cooperative sponsorship must Co-op with the nearest school that sponsors an OHSET program, **and** meets the team size conditions listed below.
- 6.2. **Definitions:**
  - 6.2.1. **Team Co-op Student(s):** attending a high school that does not offer an OHSET program applies, as a school, to compete with a high school that does offer an OHSET program.
  - 6.2.2. **District Co-op-School(s):** apply to compete in a district outside their OHSET district boundaries.
  - 6.2.3. State Co-op-State(s) ~ other than Oregon apply to compete as an OHSET District(s).
  - 6.2.4. **Applying Team:** The school that does not offer an OHSET team and is applying to compete with another school.
  - 6.2.5. **Sponsoring Team:** The school that will compete under its own name, and wishes to integrate the applying school's students for OHSET competitions.
  - 6.2.6. **Fundamental Rule:** It is a fundamental rule of OHSET that a student must attend and represent

only the public school located within the public school attendance boundaries of the student's place of residence with parents or guardian.

- 6.2.7. **Home School Students:** a student, who meets the home schooled eligibility standards established by Oregon law, may represent a school located within the school's attendance boundaries in which the student and parents of the student reside.
- 6.2.8. **Recruitment, or "undue influence"** is that attempt by any person (including but not limited to coaches, advisors, trainers, boosters, teachers, or administrators) to induce a student to attend/participate at a public or private school for purpose of athletic program participation.
- 6.3. **Team CO-OP**
- 6.3.1. Sponsoring teams having more than nine (9) student athletes will not be allowed to co-op teams.
- 6.3.2. Applying teams with more than four (4) student athletes will not be allowed to co-op.
- 6.3.3. Both of the co-op teams must submit in writing, addressed to the State Board, on the Proper form to the District Secretary for review by the District Board of Directors stating who the applying school is and who the cooperative school is.
- 6.3.3.1. The Principal, Athletic Director or Authorized school official of the sponsoring school must sign the application.
- 6.3.3.2. The Principal, Athletic Director or Authorized school official of the applying school must be informed of the application.
- 6.3.3.3. If the officials deny cooperation, the Board of Directors (district level) may follow through to ascertain the reasons for this decision.
- 6.3.3.4. Each completed application will be reviewed for approval at the next regular meeting, District or State, following receipt of application.
- 6.3.4. Team Co-op deadline is January 15.
- 6.4. **District CO-OP**
- 6.4.1. Criteria to be considered by Applicant: District(s) and State(s) Geographical District boundaries,
- 6.4.2. projected district growth, and /or economical issues.

equines are defined as equines 5 yrs old and under)

14. Side Pulls

29.3. **Optional Equipment**

1. Gloves
2. Rope or Riata: if used, the rope or riata must be coiled and attached to the saddle
3. Western spurs
4. Protective boots, leg wraps, bandages

30.



**Identity Zone**  
marketing + apparel + promotions

**Central Oregon's Premiere Source for  
Screen Printing, Embroidery  
and Promotional Products**

**Give Us A Call!**  
**800/306-2213**  
**www.theidzone.com**  
**43 NW Cherry Lane Suite 105 • Madras, OR 97741**

**28.2. Prohibited Equipment:**

1. Jerk lines
2. Tack collars
3. Chaps & ½ Chaps
4. Whips, Crops or bats
5. Slip or gag bits
6. Wire chin straps regardless of padding or covering
7. Any chin strap narrower than ½ inch
8. Martingales and draw reins
9. Sidesaddle or any type of English saddle
10. Snaffles or Bosals on equine 6 years of age and older. (Documentation of equine's age may be requested. - Junior equines are defined as equines 5 yrs old and under)
11. Side Pulls
12. Split Reins

**28.3. Optional Equipment:**

1. Gloves
2. Western spurs
3. Nosebands and Tie downs (secured to or behind a breast collar)
4. Chinks

**29. Reining:**

Reference Rules USEF Chapter "RN"

**29.1. Required Equipment**

Western saddle with horn.

There shall be no discrimination against any standard western bit.

All snaffle bits and rawhide Bosals may only be used on junior equine.

**29.2. Prohibited Equipment**

- Jerk lines
2. Tack collars
  3. Chaps & ½ Chaps
  4. Whips, Crops or bats
  5. Slip or gag bits
  6. Wire chin straps regardless of padding or covering
  7. Any chin strap narrower than ½ inch
  8. Martingales and draw reins
  9. Sidesaddle or any type of English saddle
  10. Nose bands and tie-downs
  11. Chinks
  12. Roping reins
  13. Snaffles or Bosals on equine 6 years of age and older. (Documentation of equine's age may be requested. - Junior

6.4.3. The applying High school(s) must submit in writing to their district on proper OHSET application form. The current District must approve co-op.

6.4.4. The current District sends request to sponsoring District, addressed to the State Board, on the proper OHSET application form to the District Secretary for review by the District Board of Directors stating who the school is and who the sponsoring district is. The Sponsoring District must approve co-op.

6.4.5. District Co-op deadline is the January State Board meeting

**6.5. State(s) CO-OP**

6.5.1. Criteria to be consider by applicant: OHSET district(s) and states geographical district boundaries, projected district or state(s) growth, and/or economical issues.

6.5.2. The applying state organization must submit in writing from their organization on the proper OHSET application form. The OHSET State Board must approve co-op.

6.5.3. State Co-op deadline is the January 15.

**6.6. Team CO-OP Procedure for Approval**

6.6.1. The Principal, Athletic Director or Authorized school official of the sponsoring school must sign application.

6.6.2. The Principal, Athletic Director or Authorized school official of the applying school must be informed of the application.

6.6.3. The application is brought to the District Board to be approved or disapproved. If approved, the District signs and forwards the application to the State Board.

6.6.4. The application is brought to the State Board to be approved or disapproved by a majority vote of the State Board of Directors.

6.6.5. Each completed application will be reviewed at the next regular meeting, District or State, following receipt of Co-op application form.

6.6.6. Team Co-op's will be approved for 1 year.

**6.7. District CO-OP Procedure for Approval**

6.7.1. The application is brought to the Current District's Board to be approved or disapproved. If approved, the Current District signs and forwards the application to the Sponsoring District.

## WESTERN CLASSES

- 6.7.2. The application is brought to the Sponsoring District's Board to be approved or disapproved. If approved, the sponsoring District signs and forwards the application to the State Board.
- 6.7.3. The application is brought to the State Board to be approved or disapproved by a majority vote of the State Board of Directors.
- 6.7.4. Each completed application will be reviewed at the next regular meeting, District or State, following receipt of co-op application form.
- 6.7.5. District Co-op's will be approved for one (1) year.
- 6.8. **State CO-OP Procedure for Approval**
- 6.8.1. The Authorized organization official of the applying State must sign the application.
- 6.8.2. The State approved application is to be sent to the OHSET State Board to be approved or disapproved by a majority vote of the OHSET State Board of Directors.
- 6.8.3. Each completed application will be reviewed at the next regular State meeting, following receipt of co-op application form. State Co-op's will be approved for 2 years.
- 6.9. **Private Schools** are a unique situation which requires special attention from OHSET in regards to Co-op application. If the private school allows a co-op situation then the school will apply for sponsorship with the public school that is closest to that school. If the school will not cooperate in the sponsorship of a team by another school then the athletes at that school would be treated as home schooled and each would ride with the public school that is closest to where their parents or guardians reside. OHSET would not consider a private school accepting sponsorship of a team AND allowing of individual athletes to ride under the home school rule. The private school would have the luxury of either accepting the sponsorship of the OHSET school or the home school rule, not both.

### 27. **Stock Seat, Western Trail**

Reference Rules USEF Chapter "EQ" and "WS"

#### 27.1. **Required Equipment:**

Western saddle with horn.

There shall be no discrimination against any standard western bit.

All snaffle bits and rawhide Bosals may only be used on junior equine.

#### 27.2. **Prohibited Equipment:**

1. Jerk lines
2. Tack collars
3. Chaps & ½ Chaps
4. Whips, Crops or bats
5. Slip or gag bits
6. Wire chin straps regardless of padding or covering
7. Any chin strap narrower than ½ inch
8. Martingales and draw reins
9. Sidesaddle or any type of English saddle
10. Nose bands and tie-downs
11. Chinks
12. Protective boots, leg wraps, and bandages
13. Roping reins
14. Snaffles or Bosals on equine 6 years of age and older. (Documentation of equine's age may be requested. - Junior equines are defined as equines 5 yrs old and under)
15. Side Pulls

#### 27.3. **Optional Equipment:**

1. Gloves
2. Rope or Riata: if used, the rope or riata must be coiled and securely attached to the saddle
3. Western spurs

### 28. **Working Rancher**

#### 28.1. **Required Equipment:**

1. Western saddle with horn.
2. There shall be no discrimination against any standard western bit.
3. All snaffle bits and rawhide Bosals may only be used on junior equine.
4. Roping, Romel or Mecate reins
5. Rope

## FLAG RACE Individual

**Section 1:** Two containers are placed 100 feet apart. The first container shall be 20 feet from the starting line. Sticking in the soil of each container will be a staff to be a minimum of 1 inch and a maximum of 1-1/16 inch fir or hemlock doweling, 5 feet long, painted white, bottom inch tapered to a dull point. Flag to be a sturdy cotton (double thickness, hemmed, 8 inches by 12 inches) one white and one dark, wrapped completely around the top of the staff and tacked securely, leaving an 8 inch by 8 inch portion free from staff.

**Section 2:** Rider crosses starting line, goes to first container taking that flag from container and going around second container, exchanges flag in container, goes back to first container and places flag from the second container into the first container, then crosses the finish line.

### TWO MAN BIRANGLE:

**Section 1:** Two poles 30 feet apart shall be placed 120 feet down the course from the start/finish line.

**Section 2:** First rider turns either pole from the inside out, then turns the opposite pole from the outside in (either two left or two right turns). Then rider races across finish line. The second rider is to run the same course, having the option of which direction to turn first.

---

### CANADIAN FLAG RACE Team of Four:

**Section 1:** Four flags 42 inches in length shall be spaced at 2 foot intervals, one end in the ground no more than 6 inches, with the first flag 100 feet from the starting line, which is also the finish line, and the fourth flag 106 feet from the starting line.

**Section 2:** First rider races down around all flags, picks up flag farthest from the starting line and brings it back across the finish line. Remaining riders follow the same action each taking the farthest flag in line until all have completed the course.

**Section 3:** Any flag knocked down must be picked up by the corresponding rider in his own turn.

**Source:** *Western Horsemen of Oregon, Pattern Racing Website:*

## 7. Scoring/Placing

### 7.1. Point System

1st	20 pts	9 <sup>th</sup>	8 pts
2 <sup>nd</sup>	18 pts	10 <sup>th</sup>	7 pts
3 <sup>rd</sup>	16 pts	11 <sup>th</sup>	6 pts
4 <sup>th</sup>	14 pts	12 <sup>th</sup>	5 pts
5 <sup>th</sup>	12 pts	13 <sup>th</sup>	4 pts
6 <sup>th</sup>	11 pts	14 <sup>th</sup>	3 pts
7 <sup>th</sup>	10 pts	15 <sup>th</sup>	2 pts
8 <sup>th</sup>	9 pts		
Participation		1 pt	

7.1.1. Method of scoring will remain consistent at the State and District level.

7.1.2. State qualifiers at the district level are not official until confirmed by the state.

7.1.3. District results must be submitted to the State Points Chair within one week of each district meet.



Phone: (503) 831-1340  
Cell: (503) 991-2287  
4975 Enterprise Rd.  
Dallas, OR 97338

Linda Boline  
Tory Boline  
Ariel Boline

7.1.4. Ties are not to be broken at any District Meet or the State Championship meet in any event, except as noted below for Team Penning and IHOR.

7.1.4.1. Points are awarded equally to all athlete/teams with scores tied at that placing except IHOR where time breaks the tie.

7.1.4.2. All athletes/teams with tied scores will receive full points for the position they are tied at.

7.1.4.3. The points for placing below the ties are awarded as usual after the number of tied positions has been subtracted from the placing. (clarification next page)

7.1.4.4. **EXAMPLE:**

**Tie for 1<sup>st</sup>. No 2<sup>nd</sup> place or 2<sup>nd</sup> place points awarded**

score 90 1<sup>st</sup> - 20 pts  
(qualifies as a 1,2,3 finish)

score 90 1<sup>st</sup> - 20 pts  
(qualifies as a 1, 2, 3 finish)

score 89 3<sup>rd</sup> - 16 pts  
(qualifies as a 1, 2, 3 finish)

score 88 4<sup>th</sup> - 14 pts  
(does NOT qualify as a 1, 2, 3 finish)

score 87 5<sup>th</sup> - 12 pts

**Tie for 2<sup>nd</sup>. No 3<sup>rd</sup> place or 3<sup>rd</sup> place points awarded**

score 90 1<sup>st</sup> - 20 pts  
(qualifies as a 1, 2, 3 finish)

score 89 2<sup>nd</sup> - 18 pts  
(qualifies as a 1, 2, 3 finish)

score 89 2<sup>nd</sup> - 18 pts  
(qualifies as a 1, 2, 3 finish)

score 88 4<sup>th</sup> - 14 pts  
(does NOT qualify as a 1, 2, 3 finish)

score 87 5<sup>th</sup> - 12 pts

**Clarification 1: In Hand Obstacle Relay (IHOR)** – ties in total score awarded at a meet are broken by lowest time. If still tied, tie is not broken. IHOR ties in year end point totals in a district are NOT broken.

**Clarification 2: Team Penning** – OHSET rules used to sort number of goes cows are penned; number of cows penned, and total time. If still tied, tie isn't broken.

**FIGURE EIGHT STAKE RACE:**

**Section 1:** Four poles are to be used: Two set 120 feet apart at opposite ends of the course with two center poles set 30 feet apart at a point half-way between the two end poles. These two center poles will mark the starting and finish line.

**Section 2:** Rider starts between two center poles and runs a figure “8” around the two poles; first turn optional.

**TEXAS BARRELS~ Individual:**

**Section 1:** Three barrels shall be placed in a triangular formation. No. 1 and No. 2 barrels are set 33 feet from the start/finish line and 60 feet apart. No. 3 barrel is 80 feet from No. 1 and No. 2 barrels. To square barrels with arena measure as follows: 30 feet from middle of starting line (in line with starting line) then 33 feet to barrel and 107 feet 7 inches back to middle of starting line, making a triangle.

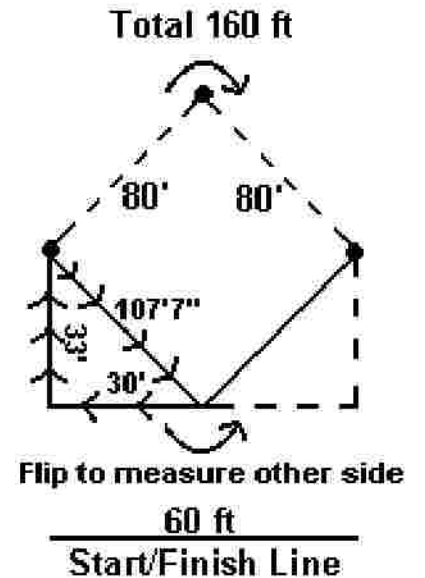

**Section 2:** Rider crosses starting line, circles No. 1 barrel to right, crosses to No. 2 barrel, circles it to left, rides to No. 3 barrel, circles it left and races across the finish line; OR crosses starting line to No. 2 barrel, circle it to left, crosses to No. 1 barrel, circles it to right, runs to No. 3 barrel, circles it to right and races across finish line.

**Section 3:** Barrel Weights: Metal Barrel 50 to 55lbs. Rounded Plastic Barrel 45 to 50lbs. Plastic Barrel with rimmed bottom 30 to 35lbs.

## POLEBENDING ~Individual:

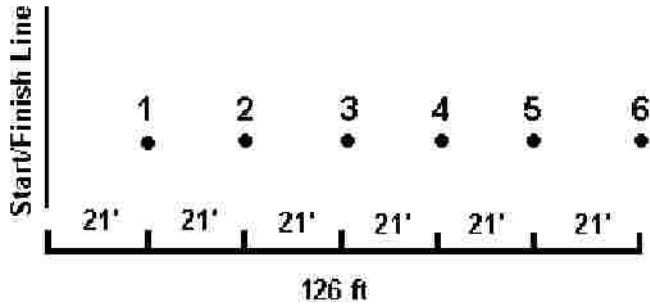

**POLES:** (Optional) To be white with a 3 inch red or blue stripe 1 foot from top and another down 1 foot from that.

**POLE BASES:** Black rubber base, 14lbs., 6 inches tall, 14 inches across. Total weight, with pole and converter, approximately 16lbs.

**Section 1:** Six poles shall be set in a straight line, spaced 21 feet apart with the start/finish line 21 feet in front of the first pole.

**Section 2:** The rider crosses the start line, races to No. 6 pole, pivots and bends back through poles, pivoting No. 1 pole, bends back through poles, turns and races across finish line.

**Section 3:** Standard 1" pole schedule 40 or 80 white plastic pipe, 80 to 81 inches long.

**Section 3A:** Plastic converter to be used to secure pole in base either by a cotter-key or gluing together.

## 7.2 Team Points

7.2.1 Team points, including participation points, are double the individual points.

7.2.1.1 Schools are to be allowed to field as many event teams as they would like.

7.2.1.2 If a school has more than one team in a team event, only the top team's score is counted toward total team points. No Participation points given to remaining teams from the same school.

7.2.1.3 In Drill, at a District meet, a school may earn meet team points from only one drill team-their highest placing drill team from either short program or working fours, but not both.

7.2.2 Districts may limit event teams if needed.

7.2.3 All team points are tracked for State qualification.

## 7.3 Individual Points

7.3.1 Junior Varsity points are not awarded to the team or year-end high-point team award.

7.3.2 The Junior Varsity athlete will receive individual points and be eligible for individual year-end awards and state qualifying.

## 7.4 Disqualification (No points awarded)

7.4.1 Points are NOT given for disqualifications.

7.4.1.1 If an athlete/team is disqualified from an event for any reason, the athlete/team and school team will not receive a point, including participation points.

7.4.1.1.1 Disqualification will be given for prohibited equipment.

7.4.1.1.2 An athlete may be disqualified for cruelty to horse or persons

## 7.5 Elimination (Participation point awarded)

7.5.1 Eliminated athletes/teams will receive participation point(s).

7.5.2 Eliminations include:

7.5.2.1 Three combined refusals in Hunt Seat Equitation Over Fences.

7.5.2.2 "Off Course" in Hunt Seat Equitation Over Fences.

7.5.2.3 No Times in timed or cow events.

7.5.2.4 Unintentionally grounded athlete

- 7.5.2.4.1 Defined in performance events as: becoming dismounted, not of their choosing.
- 7.5.2.4.2 Defined in Timed and Cattle Events as: becoming dismounted, not of their choosing, however, the athlete shall have the opportunity to remount and continue only if their equine has remained “ground tied”(has not moved more than one equine length from the rider). If not ground tied, then eliminated.

7.5.3 Eliminated athletes will not be eligible for placing points.

**7.6 Off Course**

7.6.1 Athletes will receive ZERO (0) points for the elements of the pattern that are “off course” or not attempted (including reining).

7.6.1.1 Refer to Dressage rules for an exception.

7.6.2 The “off course” athlete will not be disqualified or eliminated.

7.6.2.1 Refer to Hunt Seat Equitation Over Fences for an exception.

7.6.3 All other element scores will be tallied and awarded to athlete.

**8. Year End District Points**

- 8.1. An accurate point count must be kept for every event in the competition and points compiled at the end of the district’s competition season.
- 8.2. Each individual/team’s points for all three meets will be added together for ranking.
- 8.3. Athletes may qualify for a maximum of 5 individual year-end awards or state qualification.
  - 8.3.1 State Qualifiers at the district level are not official until confirmed by the state.
- 8.4. Participation points alone cannot qualify an athlete or team for year-end award or the State Championship.
- 8.5. Ties in yearend district point totals are not broken.
- 8.6. **Average Event/Class Size**
  - 8.6.1. For each district meet, add up the total number of athletes/teams that competed in that event.
    - 8.6.1.1. No-shows and scratches do not count toward event total.

**EVENT DESCRIPTIONS**

**KEYHOLE RACE:**

**Section 1:** A keyhole will be marked with lime according to the diagram included with this event.

**Section 2:** At the starting signal, rider crosses the starting line, races into the circle of the keyhole, turns his horse and returns across the starting line. All four (4) feet must go into the circle.

**Section 3:** Stepping on, or outside any lines of the keyhole will disqualify the horse and rider. A judge must be at the keyhole to decide upon these disqualifications, and his/her decision shall be final.

**Section 4:** It will be considered off course when horse goes by (with all 4 feet) entrance lines.

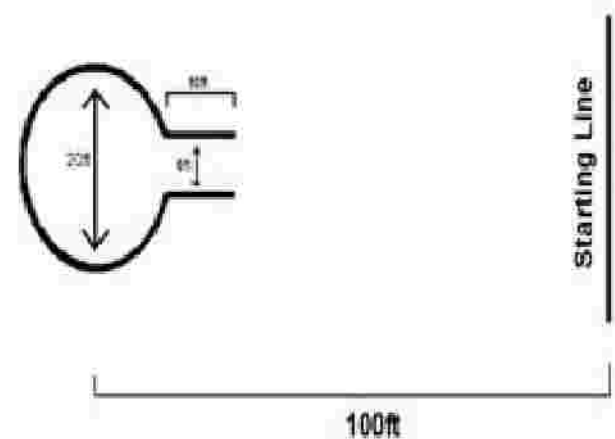

- 26.7.6. Circling (e.g. turning) around any marker (e.g. figure 8 pole) considered part of the course before crossing the starting line when mounted.
- 26.8. Athlete Disqualification: No Points Awarded
- 26.8.1. Intentionally striking the equine with arena equipment.
- 26.8.2. Abuse of the equine by any means.
- 26.8.3. Inhumane use of equipment.
- 26.8.4. Unsportsmanlike or disorderly conduct in the arena.
- 26.8.5. Use of profane language
- 26.8.6. An unmanageable equine for reasons of safety.
- 26.8.7. Loose equine: Defined as separated from and out of control of the athlete.
- 26.8.7.1. Exception: A ground tied equine (e.g. has not moved more than one equine length from the athlete) shall be considered in control.
- 26.8.8. Any athlete crossing the finish line dismounted.
- 26.9. **Team Canadian Flag/Birangle**
- 26.9.1. Contestants will be issued a **NO TIME** when two athletes are determined to be on the course at the same time.
- 26.9.1.1. The team will receive participation points.
- 26.9.2. A centerline will be identified at the start/finish line.
- 26.9.2.1. The centerline will be approximately ten (10) feet in length extending from the off-course side and perpendicular to the start/finish line.
- 26.9.2.2. The returning equine and the next equine to enter the course, should be on opposite sides of the centerline when crossing the starting line.
- 26.9.2.3. If the centerline is crossed, the judge may award the team with a “no time” (this depends on the judge’s determination of a safe or unsafe pass).
- 26.9.2.3.1. If this happens, the team will receive participation points.
- 26.10. **Team Canadian Flags**
- 26.10.1. 4-person team event.
- 26.10.1.1. If a school has only 3 riding members, they may ride this event with 3 athletes using 4 different equines.

8.6.1.2. DNF (did not finish) or DQ’s DO count toward event total.

8.6.2. Add totals for that event for all three meets. Divide by three. All fractions are rounded up.

8.7. A minimum of three (3) and up to a maximum of 10% (rounded up) of the average number of individual/team competitors identified above, of the top year end point earners in each event will qualify for the State Championship.

8.7.1. TOP 10% RULE: Multiply .10 times the average event size. If the average event size is 30 (even) or less, that event sends award winners only to state. NOTE: This may result in more than three award winners going to state if there are ties in the award placing.

8.7.1.1. If average event size is 30 plus a fraction or more, that event sends, the top 10% of the average event size.

8.7.1.2. These point results are to be submitted to the State Board of Directors for notification of State competition participants.

**Clarification 1:** All award winners qualify for State Championship, even if total number of award winners is greater than 10% of event.

**Example A:** Two athletes tied for first place in district. Average event size is 29. Both athletes tied at first place receive gold awards, 3<sup>rd</sup> highest receives silver, 4<sup>th</sup> highest receives bronze. All four qualify for State.

**Example B:** Three Team Penning teams tied for third place in district. Average event size is 30. Award gold and silver as usual, and three tied teams receive bronze awards. All five teams qualify for State.

**Clarification 2:** There is a tie at the score for the last qualifying (non-award) spot; all with that score qualify for State.

**Example A:** No ties in award placing. Average event size is 60. 10% rule would send 6 to State. There are two athletes/teams tied for sixth place. Both athletes/teams tied for sixth qualify for State.

**Clarification 3:** 10% rule determines more than award winners will qualify for State, and there is a tie at a position above the last qualifying position. The number of athletes/teams determined with the 10% rule does not increase.

**Example A:** No ties in award placing. There are two athletes tied for fourth place. Average event size is 60. 10% rule would send 6 to State.

send six to State. The event sends the top six qualifiers to state.

**Clarification 4:** If there were originally ties for placing's that qualified for State and a qualifier does not attend the State Championship, additional placing's/alternates qualify only based on the 10% Rule.

**Example A:** Three Team Penning teams tied for third in district. Average event size is 30. Award gold, silver and three bronze awards are given. All five teams qualify. Any of the qualifying teams then declines to attend. No additional (alternate) teams qualify to attend until the number of award winning teams attending the State Championship drops below three.

**Example B:** Three athletes tied for third place in district. Average event size is 60. 10% rule would send six to State. Gold, silver and bronze awards are given. The top athletes (award winners plus next highest scoring athlete) qualify for State. Any qualifying athlete declines to attend the State Championship, the first alternate is now qualified to attend, keeping the total qualifiers attending the State Championship to six.

**Example C:** No ties in award placing. There are two riders tied for sixth place. Average event size is 60. 10% rule would send six to State. Both athletes tied for sixth place qualified for State. Any qualifier declined to attend the State Championship, no additional athletes qualify to attend until the number of remaining qualifiers attending the State Championship drops below six.

**Clarification 5:** If a qualifier does not attend, and there were only three award winners originally with an event size of 30 or less, and there is a tie for the next alternate position, then all tied at that position are eligible to attend State.

**Example A:** No ties in award placings. There is a three-way tie for fourth place. Average event size is 30. The three award winners qualify for State. Any award qualifier declined to attend State, all three alternates tied for fourth place now qualify to attend.

## 9. Awards

### 9.1. District Awards

- 9.1.1. Individual and Team event, the top three places will be awarded a gold, silver or bronze medal.
- 9.1.2. Athlete must have an *official* time in order to medal in Roping and Daubing.
- 9.1.3. Each school's athlete's points from each event will be added together and at the end of the season, a

### 26.5.1. Setting and Resetting the Course

- 26.5.1.1. It is the judge's responsibility to oversee, supervise and participate in all course set up.
- 26.5.1.2. In no timed event (except Birangle) will the course be reset while the rider is on pattern.
- 26.5.1.3. In Birangle, the poles may be reset between riders if it can be done without jeopardizing safety.

### 26.6. Arena Safety

- 26.6.1. As soon as athlete takes the course arena staff must close all arena gates.
  - 26.6.1.1. Running in the gate is not allowed
  - 26.6.1.2. Gate does not have to be closed for athlete to start.
- 26.6.2. Contestants must enter and leave the arena demonstrating control.
- 26.6.3. Only contestants, coaches, advisors, ring crew and officials are allowed in the arena.
- 26.6.4. Equine that constitute a safety hazard may be disqualified.
- 26.6.5. No athletes/teams may be coached from inside the arena at the meet.

### 26.7. Athletes Off Course/Elimination: Points Awarded

- 26.7.1. Leaving the course, run outs, refusals, upsetting the starting poles.
- 26.7.2. Taking more than **30 seconds** to cross the starting line.
  - 26.7.2.1. The course begins at the start line. Announcer announces athlete, Judge raises hand to indicate course is ready, athlete has **30 seconds** to start the course whether in arena or not.
  - 26.7.2.2. The Judge will time or indicate to the timer to start the **30 seconds**. It is a Judge's call to "**No Time**" athlete if they have not taken the course.
- 26.7.3. In **Individual Flag Race**, if the athlete going on course, knocks over the first or second container and fails to reset it.
- 26.7.4. Stepping on or outside any of the marked lines of the **Keyhole Race**.
- 26.7.5. Failure of the equine to have all four feet inside the circle of the keyhole, before turning toward the finish line.

## 26. Timed Events

Reference Rules WHO Rule Book

### 26.1. Individual Events

1. Barrels
2. Figure 8
3. Individual Flags
4. Keyhole
5. Pole Bending

### 26.2. Team Events

1. Two Man Birangle
2. Team Canadian Flags

### 26.3. Required Equipment

1. Bridle or Hackamore
2. Western type saddle with horn
3. Roping, Rommel or Mecate reins

### 26.4. Prohibited Equipment

1. Halters
2. Split reins
3. Chaps/ ½ Chaps/Chinks

### 26.5. Optional Equipment

1. Slip or gag bits
2. Nose bands
3. Spurs
4. Protective boots, leg wraps, and bandages
5. Over and Under (to be inspected by judge)
6. Tie-Downs attached to or under breast collar
7. Martingales, fitted properly as to not be a danger if equine falls or athlete loses control, to be decided by judge. **Rein Stops** are required on **Running Martingales**.
8. Rope (Must be properly secured to the saddle)
9. Ribbons, paint, glitter and speed beads

team trophy will be presented to the highest team total in each district.

9.1.3.1. Junior Varsity points are not included.

9.1.4. A sportsmanship trophy will be awarded based on merit and voted on by the district.

9.1.5. District may determine other awards to be presented.

## 10. Liability

10.1. A general liability policy purchased and maintained through the OHSET Organization will cover spectators and bystanders.

10.2. Each student/athlete must supply their own health/accident insurance.

## 11. Timed Event Records

11.1. All OHSET timed events are measured and recorded to the hundredths place only (16.01). Thousandths place (16.001) if generated from electronic-eye type timers, will be dropped with **NO** rounding.

11.2. See WHO record procedures for protocol verifying course and time for gaming events.

11.3. Person holding the best time in the State at the end of the season will be named the State Record Holder, whether time is at the district or State Championship Meet.

11.4. Records will be tracked in each District and State Championship Meet for Breakaway Roping, Steer Daubing, Team Canadian Flag, Two Man Birangle,

**GOOD LUCK OHSET ATHLETES**

from

**SPECIALTY RV**

**Custom Accessories, Installations,  
Repairs and Service**

*Our specialty is  
Personalized  
Service for your  
diesel motor home.*

20781 Olmstead Rd NE  
Aurora, Oregon 97002  
(503) 678-6595

Barrels, Keyhole, Figure 8, Pole Bending and Individual Flags.

11.4.1. In Breakaway Roping, the record will be held by the participant who roped the calf with the best time in one go around.

11.4.2. In Steer Daubing, the record will be held by the athlete who daubs 1 cow with the best time.

11.5. Time is to be verified by Timer and Judge utilizing the Timed Event Record Form regardless of timed event.

11.6. Both the Judge and Timer must sign the Timed Event Record Form. Record Form is then turned into the State Secretary at next State Board meeting.

11.6.1. **There will be no ties for a timed record. An athlete must break the record for it to count.**

11.7. Report a record time, to the State Points Chair, within 4 days of the meet.

25.5.1. Any costume deemed unsafe by the judge will result in an elimination.

25.6. Readers will NOT be allowed.

25.7. Working Pairs is to be ridden in an arena using Dressage letters for orientation. The arena should be fairly close in size to a small Dressage court (65ft X 130ft approx.) **without** using any type of borders or boundaries.

\$5.00 DONATED TO  
CCHS ATHLETICS

10% STUDENT  
DISCOUNT

# Crook County Towing, LLC



*We tow your ride with .... COWBOY PRIDE!*

1623 NW Gardener Rd. • P. O. Box 1376  
Prineville, OR 97754  
PH# (541) 416-0836 • FAX# (541) 416-9346

## Burns Feed Store

Established in 1950.

10% Discount is allowed to members of 4-H, OHSET and FFA (not the leaders) on grooming products, supplements, de-warmer, halters, leads, bits, vaccines, treats, forks, gloves, books, helmets....

Discount is NOT allowed on feed, hay, salt, mats, wire, fencing, posts, corral panels, wheelbarrows.....

Hours

Monday-Friday 8am-6pm

Saturdays 8am-5pm and Sundays 10am-4pm

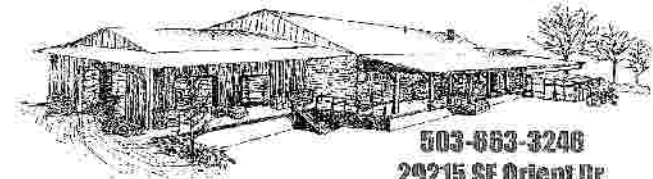

Visit our store to register for  
Email Specials and promotions:

503-863-3246  
29215 SE Orient Dr.  
Gresham, OR 97080  
Email: [burnsfeed@hdweb.com](mailto:burnsfeed@hdweb.com)

## 25. Working Pairs

### 25.1. Required Equipment:

Equine equipment shall meet requirements of OHSET for chosen style of riding

### 25.2. Prohibited Equipment:

1. Wire chin straps, regardless of how padded or covered
2. Any chin strap narrower than ½ inch
3. Draw reins
4. Jerk lines
5. Tack collars
6. Chaps
7. Skirts (Sidesaddle)
8. Bit Converters
9. Gag bits

### 25.3. Optional Equipment:

1. All humane bits regardless of horse's age (except Gag bits)
  2. Curbs may be ridden with two-hands, but all things equal, one hand on a curb will score higher.
  3. Gloves
  4. Rope or riata; if used, the rope or riata must be coiled and securely attached to the saddle.
  5. Spurs
  6. Individual Music
  7. Leg wraps
  8. Nose bands and tie downs. (The tie-down must be attached to or under the breast collar.)
  9. Martingales (Running martingales must have rein stops (Rubber or leather stops slipped onto the rein between the bit and the ring of the martingale))
  10. ½ Chaps & Chinks
  11. Side Pulls
- 25.3.1. Pairs may ride Western, Hunt Seat, Saddle Seat or Dressage style
- 25.3.1.1. Both athletes must ride the same seat
  - 25.3.1.2. Driving is not allowed.
- 25.3.2. Any age equine may use a snaffle in any style of riding.
- 25.3.3. Bosal or mechanical hackamores may be used when in western style tack.
- 25.4. Both hands may be used on the reins for English or Western Style
- 25.5. Costumes allowed on equine only

## EVENT RULES



Proudly supplying stock for  
OHSET since 2006

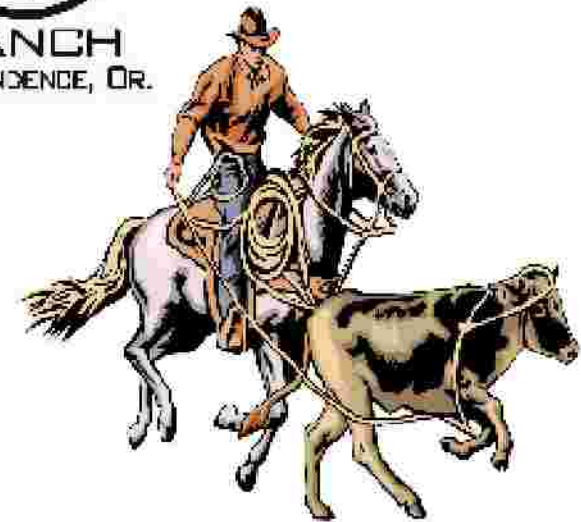

## Matt Richards Rodeo Stock

Rocking R5 Ranch Established in 1989

Pee wee to professional stock available!

\*Team Penning

\*Roping

\*Wild Cow Milking

\*Bulls

stock inquiries please call

Ranch: (503) 838-5062

Cell: (503) 871-7130

## EVENT RULES

### Cattle Events

- **Breakaway Roping**
- **Steer Daubing**
- **Team Penning**

#### 12.1. Arena Set up

- 12.1.1. Cattle events will be conducted in an arena of adequate size (e.g. =90'x200').
- 12.1.2. Arena footing conditions must allow for safe and competitive conditions.
- 12.1.3. Seating must be adequate to allow spectators to view all events

#### 12.2. Competitor Equipment Check

- 12.2.1. It is the responsibility of Coaches/Advisors, and **not that of the gate crews**, to ensure that their competitors are on time, properly uniformed and equipped for each event/class.

#### 12.3. Required Equipment:

1. Bridle or hackamore
2. Western type saddle with horn
3. Roping, Romel or Mecate reins

#### 4. Breakaway Roping Additional Requirements:

- Rope

#### 12.4. Optional Equipment:

1. Slip or gag bits
2. Hackamore (Including mechanical)
3. Tie-downs attached to/or under a breast collar
4. Protective boots, leg wraps and bandages
5. Nosebands
6. Martingales, fitted properly as to not pose a danger if horse falls or athlete loses control (To be decided by judge) **Rein Stops** (*Rubber or leather stops slipped onto the rein between the bit and the ring of the martingale*) are required with the use of Running Martingales.
7. Western Spurs (Subject to inspection by the judge)
8. Over and Under/bats (Subject to inspection by the judge)
9. Chinks
10. Rope (Daubing & Team Penning **must** be properly secured to the saddle)
11. Ribbons, paint, glitter and speed beads

24.8.1. Athletes touching their equine should not expect a zero, but will be scored accordingly.

24.9. Each team member may earn up to an additional **10 points** for the team by completing the bonus obstacle. The **four (4) mandatory** obstacles **must be attempted** before a contestant may attempt the bonus obstacle.

24.10. All team members shall be positioned behind the 30' start/finish line in the arena.

24.10.1. **Time starts** when the first handler breaks the plain of the starting line.

24.10.2. The next contestant cannot break the plain of the start line until the contestant on course (handler) has crossed the start/finish line.

24.10.2.1. This is called **scratching** (two handlers are determined to be on the course at the same time) A team in violation will be given a **10-point penalty** for each occurrence.

24.10.3. **Time shall end** when the fourth equine's rear end crosses the start/finish line.

24.11. Each Team is allowed 5 minutes to complete the course. Any teams exceeding the 5 minute allotment shall be assessed a 10 point penalty for each minute or fraction of a minute in violation.

24.11.1. Example:

24.11.1.1. 5:01 minutes - 6 minutes = -10 point penalty

24.11.1.2. 6:01 minutes - 7 minutes = -20 points,

24.12. Points will be added up for all mandatory and bonus obstacles for each contestant and added together with the other team members to determine total team score. **Penalty points will be deducted from the teams' total to determine the final team score.**

24.13. In the event of a point tie, time will be used as the tie breaker

- 23.4. This class will be using the regular trail course, with alterations to allow for animals to be shown in hand.
- 23.5. To be judged the same as a trail course.
- 23.6. After two refusals, the judge shall ask the athlete to move on to the next obstacle.
- 23.7. Bridges are crossed by equine and handler.
- 23.8. Hand aids are allowed. Athletes may not touch equine unless directed by the judge or specified in the pattern.
  - 23.8.1. Athletes touching their equine should not expect a zero, but will be scored accordingly.
- 23.9. In Hand Trail equine is not restricted to size or breed.
- 23.10. An equine used for In Hand Trail **cannot** be cross-entered as a riding animal by anyone at any OHSET competition during the season.
  - 23.10.1. This equine **may** be used in Driving, In Hand Obstacle Relay and Showmanship.

#### 24. In Hand Obstacle Relay (IHOR)

- 24.1. **Required Equipment:**
  - 1. Halter and lead rope or leather lead
- 24.2. **Prohibited Equipment**
  - 1. Bridles of any type
  - 2. Whips, crops, or bats
  - 3. Spurs
  - 4. Chaps/Chinks
- 24.3. **Optional Equipment:**
  - 1. Headgear: Western hat, English helmet, Regulation helmet or no hat of any type
  - 2. Gloves
  - 3. Nose or chin chains (for the equine)
  - 4. Leg Wraps
  - 5. Ribbons, glitter, and sparkle on horses
- 24.4. This is a 4-person Team Event.
  - 24.4.1. Schools with only 2 or 3 eligible competing athletes will be allowed to participate using 4 different equine.
- 24.5. All In Hand and Riding equine are eligible for this event.
- 24.6. Each athlete may earn up to 10 points each for navigating the mandatory obstacles.
  - 24.6.1. Athletes will be judged on performance of the handler and equine as they negotiate each obstacle.
- 24.7. Gaits between obstacles are optional unless specified by the pattern.
- 24.8. Hand aids are allowed. Athletes may not touch equine unless directed by the judge or specified in the pattern.

#### 12.5. **Prohibited:**

- 1. Roughing cattle
- 2. Rope may not pass through bridle, tie down, neck rope or any other device
- 3. Halters
- 4. Split reins even if tied or joined together
- 5. Bits or equipment that the judge may consider severe
- 6. Chaps & ½ Chaps

#### 12.6. **Judges:** There shall be two (2) judges used. (**Roping & Daubing**)

- 12.6.1. **The Flagger** will be on horse back, whenever possible, and be considered the head judge for these events.
  - 12.6.1.1. Prior to the events, the Flagger will inspect the cattle and eliminate any that he/she finds objectionable.
  - 12.6.1.2. During the events, the Flagger will determine legal catches/daubs and/or any rule infractions.
  - 12.6.1.3. In the event of a protest, only the Flagger will coordinate with the Line Judge and then, if requested, will confer with the Stewardship committee.
- 12.6.2. **Line Judge** will position him/herself at the cattle barrier line and will signal the announcer to call for the next competitor.
  - 12.6.2.1. The competitor will have sixty (60) seconds from the time their name is called until signaling they are ready for the chute to open.
  - 12.6.2.2. The Line Judge will keep this time.
  - 12.6.2.3. If the competitor is not in the box and ready (shall be defined as facing the front of the “box” and asking for the steer to be released) when that period of time is up, the Line Judge will signal the announcer and the competitor shall be awarded a “no time”.
  - 12.6.2.4. The Line Judge will monitor the competitor to ensure no rule violations while in the “box”.
  - 12.6.2.5. In the event of equipment failure during Steer Daubing or Breakaway Roping, the Line Judge will flag at the competitor line to ensure the competitor does not “break out”.

- 12.6.2.5.1. If the Line Judge determines that the competitor “broke the barrier”, a ten (10) second penalty will be assessed.

### 13. Breakaway Roping

- 13.1. This is a timed event with a 30 second limit, 2 goes per athlete.
- 13.2. The **Cattle Handlers** shall be consistent throughout the event.
- 13.3. The hazing line must remain consistent throughout the event.
- 13.3.1. If an athlete leaves the line, an athlete on horseback must replace them.
- 13.4. **Horns on Cattle**
- 13.4.1. **Meets** shall have the option of using horned Cattle. **No horns are preferred.**
- 13.4.1.1. If cattle are horned, horns are not to exceed two (2) inches at state meets.
- 13.5. Athletes will be allowed to come out of either side of the box.
- 13.5.1. Athletes **MUST** have their equine facing OUT of the box before they ask for the steer to be released.
- 13.5.2. A coach, advisor or adult (non-athlete) may bring the equine in the arena and/or into the box.
- 13.5.3. Any physical encouragement of forward motion or holding back by anyone other than the rider will be an elimination for that go.
- 13.6. **If a box is not available**, a line will be drawn six (6) feet from the release end of the chute.
- 13.7. There are **three (3) barrier options**:
- 13.7.1. Judge at line
- 13.7.2. Rope
- 13.7.3. Electric eye, will be used at the **State Championship**.
- 13.8. The cow’s nose must break the six (6) foot barrier for the equine to leave the box.
- 13.8.1. A ten (10) second penalty for **breaking the barrier** will be added.
- 13.9. Two (2) loops will be permitted. It is an option to rebuild or carry the 2<sup>nd</sup> loop.
- 13.9.1. One (1) or two (2) ropes are to be tied to the saddle horn by a heavy string, (90lb test) in such a manner as to allow the rope to be released from the horn when the calf reaches the end of the rope.

### 22. Showmanship

Reference Rules OHA

#### 22.1. Required Equipment:

1. Halter and lead rope or leather lead
2. Lead shall be 6’ to 8’ in length

#### 22.2. Prohibited Equipment

1. Bridles of any type
2. Whips, crops, or bats
3. Spurs
4. Chaps/Chinks
5. Leg Wraps
6. Ribbons, glitter, and sparkle on equine

#### 22.3. Optional Equipment:

1. Gloves
2. Nose or chin chains
3. Headgear: Western hat, English helmet, Regulation helmet or no hat of any type

22.4. Equine may be shown according to breed specifications

22.5. Showmanship is a demonstration of the athlete’s ability to show the equine to the best advantage in a halter

22.6. Conformation is not to be considered

22.7. Hand aids are allowed, athletes may not touch equine unless directed by the judge or specified in the pattern.

22.7.1 Athletes touching their equine should not expect a zero, but will be scored accordingly.

### 23. In Hand Trail

#### 23.1. Required Equipment

1. Halter and lead rope or leather lead

#### 23.2. Prohibited Equipment:

1. Bridles of any type
2. Whips, crops, or bats
3. Spurs
4. Chaps/Chinks
5. Leg Wraps
6. Ribbons, glitter, and sparkle on equine

#### 23.3. Optional Equipment:

1. Headgear: Western hat, English helmet, Regulation helmet or no hat of any type
2. Gloves
3. Nose or chin chains

# GOOD LUCK AMARA, JESSICA



**...AND GOOD LUCK  
TO THE ENTIRE  
MOLALLA OHSET  
TEAM YOU'RE THE  
BEST**

- 13.9.2. A visible **cloth or flag** must be attached to the end of the rope tied to the horn to make it easier for the Flagger to see it break free.
- 13.10. A **legal catch** is to be any loop that goes **completely** over the calf's head and draws up on **any** part of the calf's body (except the tail) causing the rope to break away from the saddle horn.
- 13.11. **Time will be started** from the drop of the Line Judge's flag at the barrier or by Electronic Timer.
- 13.12. **Time will be stopped** when indicated by the Flagger Judge dropping the flag after the rope-string breaks from the saddle horn.
- 13.13. The athlete shall be awarded a "**no time**" in the following situations:
- 13.13.1. he/she break the rope from the horn by hand, touch the rope or string after the catch is made or if the rope dallies around the horn and/or does not break free when the calf reaches the end.
- 13.13.2. Roping the calf without releasing the loop from the hand
- 13.13.3. Any attempt by an athlete to position his/her equine in the box enabling himself/herself to rope the calf without leaving the box
- 13.13.4. If athlete has not entered the chute and called for their calf within sixty (60) seconds from the time their name is called
- 13.13.5. **If an athlete becomes grounded** during their go, they shall have the opportunity to remount and continue only if their equine has remained ground tied (e.g. has not moved more than one (1) equine length from the athlete). Otherwise, a "no-time" shall be awarded for that go.
- 13.14. **Re-Rides**
- 13.14.1. An athlete must request a re-ride, from the Flagger Judge, prior to throwing his/her first loop and before leaving the arena.  
(Note: An example of where a re-ride could be requested would be if the calf cuts through the hazing line after it has crossed the barrier and does not allow the athlete an opportunity to throw a loop.)
- 13.15. **Placing will be determined** first by the number of successful catches, then lowest total time.
- 13.16. State records will be tracked by single fastest time.

#### 14. Steer Daubing:

- 14.1. This is a timed event with a fifteen (15) second limit, two (2) goes per athlete
- 14.2. **Equipment for Arena**
  1. A four (4) foot dauber with a tennis ball.
  2. A “bright contrasting color paste” to coat the tennis ball end of the dauber
- 14.2.1. There are two (2) **Timing Options:**
  1. Electronic Eye.
  2. Stop Watches
- 14.3. The Cattle Handlers shall be consistent throughout the event
- 14.4. The hazing line must remain consistent throughout the event.
  - 14.4.1. If an athlete leaves the line, an athlete on horseback must replace them.
- 14.5. **Horns on Cattle**
  - 14.5.1. Meets shall have the option of using horned cattle. **No horns preferred.**
    - 14.5.1.1. If cattle are horned, horns are not to exceed 2 inches at state meets.
- 14.6. Athletes will be allowed to come out of either side of the box.
  - 14.6.1. Athletes **MUST** have their equines facing **OUT** of the box before they ask for the steer to be released.
  - 14.6.2. A coach, advisor or adult (non-athlete) may bring the equine in the arena and/or into the box.
  - 14.6.3. Any physical encouragement of forward motion or holding back by anyone other than the rider will be an elimination for that go.
- 14.7. **If a box is not available**, a line will be drawn six (6) feet from the release end of the chute.
- 14.8. The cow’s nose must break the six (6) foot barrier for the equine to leave the box.
  - 14.8.1. A ten (10) second penalty for breaking the barrier will be added.
- 14.9. A **successful daub** is placed inside of an imaginary box formed between the “wither like” area and the tail head and the top of the back and a **line** between the knee and the hock, exclusive of the tail.

#### 21. Saddle Seat Equitation, Saddle Seat Trail

Reference Rules USEF Chapter “EQ” – Subchapters: Eq-1 & Eq-3

##### 21.1. **Required Equipment:**

1. Cutback Saddle
2. Full Bridle (curb and snaffle) or
3. Pelham Bridle, single bit with two (2) sets of reins
4. Gaited Horses may use breed specific bridles - Single curb bit with a single rein.

##### 21.2. **Prohibited Equipment:**

1. Draw reins
2. Non-English type spurs
3. Western, dressage, hunt seat or sidesaddles
4. Bit converters
5. Gag Bit
6. Ribbon, Glitter, & Sparkle (Exception: Residual from Working Pairs when scheduling does not allow its removal.)
7. Any bit with a twist in the metal
8. Figure 8, Flash, or dropped nose
9. Martingales
10. Protective boots, leg wraps and bandages
11. Side Pulls

##### 21.3. **Optional Equipment**

1. Spurs of an English type
2. Crops, bats, or whips may be no longer than 44” including lash
3. Gloves
4. English breast plate
5. ½ Chaps

- 21.4. The terminology of “*intermediate gait/trot*” will be included in gait descriptions in patterns



# This ain't no pony ride.

Best of luck to our OHSET competitors  
from the high schools of Tri-River Valley!



Oregon City  
Pioneers



Molalla  
Indians



West Linn  
Lions



Tigard  
Tigers



Tualatin  
Timberwolves



Lakeridge  
Pacers



Lake Oswego  
Lakers



Wilsonville  
Wildcats



Colton  
Vikings

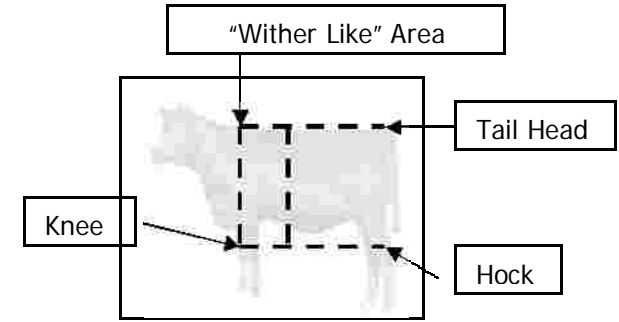

- 14.10. Athlete must raise the four (4) foot dauber above his/her head to indicate a successful daub.
- 14.11. **Time starts** at the drop of the Line Judge's flag at the barrier
- 14.12. **Time stops** when the Flagger Judge drops his/her flag.
- 14.13. The athlete shall be awarded a "**no time**" in the following situations:
  - 14.13.1. If time is called by the athlete and a mark is not visible on the steer
  - 14.13.2. If the dauber is thrown at the steer or dropped by athlete
  - 14.13.3. Any attempt by an athlete to position his/her equine in the box enabling him/her to daub the steer without leaving the box.  
If the athlete has not entered the chute and called for it to be opened within sixty (60) seconds from the time their name is called.
  - 14.13.4. **If an athlete becomes grounded** during their go, they shall have the opportunity to remount and continue only if their equine has remained ground tied (e.g. has not moved more than one equine length from the athlete). Otherwise, a **no time** shall be awarded for that go.
- 14.14. **Re Rides**
  - 14.14.1. An athlete must request a re-ride from the flagger judge prior to attempting to daub and before leaving the arena. (An example of where a re-ride could be requested would be if the steer stops and cuts back through the hazing line after it has crossed the barrier and does not allow the athlete an opportunity to attempt a daub.)
- 14.15. **Placing will be determined** first by the number of goes with successful daubs, then lowest total time.

14.15.1. State Records will be tracked by single fastest time

## 15. Team Penning

### 15.1. Team Penning Arena Set-Up

15.1.1. The cattle holding area will be screened from the competitive arena to prevent the active herd from bunching next to the herds waiting rotation.

15.1.2. **The start/foul line** will be at the distance of 35% of the arena. The pen will be at the distance of 25% (but not less than 55 feet) from the back of the arena.

### 15.2. Barriers/Timers

15.2.1. Electronic Barriers/Timers are the preferred barrier/timing devices and will be used during the State Championship.

15.2.2. A “back-up” timer with two stop watches will be positioned next to the announcer. The back-up timer will time each team

15.2.2.1. In all cases, the faster time of the two watches will be used.

15.2.2.2. In the event of timer equipment failure, time will start with the Line Judge drops his/her flag when the team crosses the 35% line and stops when the Pen Judge/Line Judge drops his/her flag when the team calls for time, and/or has all un-penned cattle back across the line.

15.3. A **team shall be defined** as three (3) or four (4) members.

15.3.1. One alternate may be chosen from the alternate pool at any time.

15.3.2. Any three of the four (4) members may ride any go, any meet, and points will count for that team.

15.3.3. Schools having only two (2) registered competing athletes, may field a two-person Team Penning Team.

15.4. **Determining Order of Go.** Districts may adopt either the State formula below or their own so long as it adheres to all herd and other rule requirements. (i.e. not penning on the same herd more than once.)

15.4.1. **At the State Meet** the placement of Teams in the first go shall be by a blind draw. Thereafter, teams shall stay together within the group formed by their ‘herd change’. For the second and third goes, the team order will rotate so as to have each team pen

## 20.2. Prohibited Equipment:

1. Draw reins
2. Non-English type spurs
3. Western, sidesaddles, Saddle Seat style cutback saddle, dressage saddle
4. Bit Converters
5. Gag Bit
6. Ribbon, Glitter, & Sparkle (Exception: Residual from Working Pairs when scheduling does not allow its removal.)
8. Any bit with a twist in the metal
9. Side Pulls

## 20.3. Optional Equipment:

1. Figure 8, Flash, Dropped nosebands
2. Protective boots, leg wraps and bandages
3. Martingales : Running martingales must have rein stops (Rubber or leather stops slipped onto the rein between the bit and the ring of the martingale)

20.4. **Fences** shall not exceed a maximum height or spread of 2 feet, 9 inches

## 20.5. Qualifying

20.5.1. Athlete shall jump 2 fences, observed by the officiating Judge prior to the start of the class

20.5.1.1. The officiating judge shall determine if the athlete and/or equine are competent to ride the class

20.5.1.2. The judge may excuse any athlete deemed unsafe

20.5.1.3. The decision of the judge shall be final.

## 20.6. Elimination

20.6.1. Fall of equine and/or athlete

20.6.2. Off Course

20.6.3. Three (3) combined refusals.

20.6.3.1. Eliminated athletes will not be eligible for placing points

20.6.3.2. At the Judge’s discretion, an **eliminated** athlete may jump an additional fence, but may not continue thereafter.

#### 18.9.4. **Eliminations**

- 18.9.4.1. Three errors of/on the test
- 18.9.4.2. Failure to enter the court within 45 seconds of the Judge ringing the bell
- 18.9.4.3. Equine stepping all four feet outside of the court during the test.

#### 19. **Hunt Seat Equitation, Hunt Seat Trail**

Reference Rules USEF Chapter "EQ"

##### 19.1. **Required Equipment:**

1. Forward Seat Saddle
2. Multipurpose, English type saddle
3. Regulation Snaffle, Pelhams, Full Bridles, Kimberwicks, all with Cavesson nosebands.

##### 19.2. **Optional Equipment:**

1. Spurs of an English type
2. Crops, bats, or whips may be no longer than 30" including lash
3. Gloves
4. English Breast Plate
5. Braiding of mane or mane and tail in hunt style
6. ½ Chaps

##### 19.3. **Prohibited Equipment:**

1. Draw reins
2. Non-English type spurs
3. Western, sidesaddles, Saddle Seat style cutback saddle, dressage saddle
4. Bit Converters
5. Gag Bit
6. Ribbon, Glitter, & Sparkle (Exception: Residual from Working Pairs when scheduling does not allow its removal.)
8. Any bit with a twist in the metal
9. Figure 8, Flash, or Dropped nose band
10. Martingales
11. Protective Boots, leg wraps and bandages
12. Side Pulls

#### 20. **Hunt Seat Equitation Over Fences**

Reference Rules USEF Chapter "EQ" & "HU"

##### 20.1. **Required Equipment:**

1. Forward Seat Saddle
2. Multipurpose, English type saddle
3. Regulation Snaffle, Pelhams, Full Bridles, Kimberwicks, all with Cavesson nosebands.

in the first, second, and third, portion of their 'herd change'.

#### 15.5. **Horns on Cattle**

- 15.5.1. Meets shall have the option of using horned cattle. **No horns, are preferred.**
- 15.5.2. If cattle are horned, horns are not to exceed 2 inches .

#### 15.6. **Judges for Team Penning**

- 15.6.1. **Two** Judges shall be used.
- 15.6.2. **The Pen Judge** acts as the head judge for this event and will position him/her to view the pen opening. In the event of a protest, the Pen Judge will coordinate with the Line Judge and then, if requested, will confer the Stewardship committee.
- 15.6.3. **The Line Judge** will position him/herself at the 35% foul line. The Line Judge is responsible for checking each herd as it enters the arena for correct head count, proper numbering, and number readability. The Line Judge will then signal the announcer to call the next team.

#### 15.7. **The Event.**

- 15.7.1. This is a timed event with a ninety (90) second limit and three (3) goes per team.
- 15.7.2. The herd is held in a tight group in the center of the wall at the herd end of the arena by the previous team.
  - 15.7.2.1. Herds shall be the same size within any single competition and will consist of between 18 and 27 head.
  - 15.7.2.2. A minimum of one number shall remain uncalled in each herd.
  - 15.7.2.3. Teams will not be asked to pen on the same herd twice during a meet.
- 15.7.3. When the **Line Judge** determines the cattle are ready he/she signals the announcer by raising his/her flag.
- 15.7.4. When the announcer calls "cattle are ready," the holding team rides to the exit, along the walls of the arena, and the competing team rides to the herd.
- 15.7.5. The competing team has thirty (30) seconds to cross the time line or a no time will be awarded.
- 15.7.6. Upon the team crossing the time line the Line Judge drops his/her flag, the announcer calls the number of the cattle to be penned, and the timers start their watches.

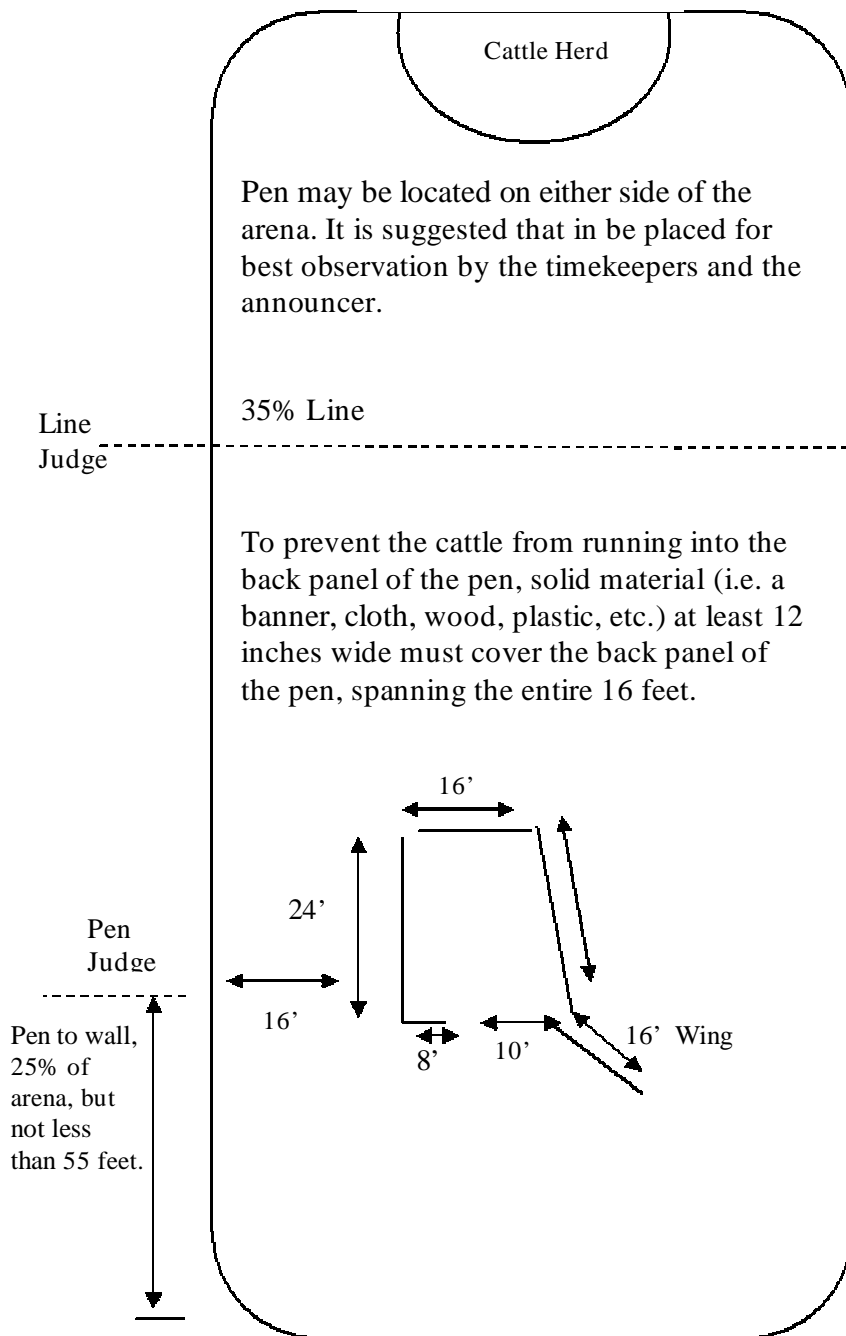

- 18.4. Judging shall be consistent with USDF rules  
 Harmonious development of the physique and ability of the horse as demonstrated by
1. The freedom and regularity of the gaits
  2. The harmony, lightness and ease of the movements
  3. The lightness of the forehand and the engagement of the hindquarters
  4. The acceptance of the bridle with submissiveness throughout
  5. Flowing circles
  6. Resistance-free bending with flexion while creating a rhythm in the test will score higher.
  7. Relaxed posture and horsemanship skills on the part of the athlete should make each element look effortless
- 18.5. Use of a caller is allowed
- 18.6. Fall of horse or rider shall not be an elimination.  
 The effect of the fall will be reflected in the movement score and the collective marks
- 18.7. **Errors**
- 18.8. Examples of errors
1. Use of voice in any way
  2. Wrong turns
  3. Omitting a movement
  4. Movement incorrectly ridden
  5. Wrong gait
  6. Posting instead of sitting or visa versa
- 18.9. **Judging Errors**
- 18.9.1. Shall deduct 2 points for the first occurrence, 4 points for the 2<sup>nd</sup> occurrence, 6 points for the third occurrence
- 18.9.1.1. After the third error, the athlete will be eliminated
- 18.9.2. The Judge may choose to ring the bell for an error *on* the test. For example, the rider turns the wrong way or omits a movement. The Judge will instruct athlete as to the nature of the error. Athlete re rides the test from the point directed by the judge. The error is scored as above
- 18.9.3. The Judge may choose not to ring the bell for an error *of* the test. Rider incorrectly rides a movement such as posting instead of sitting, incorrect salute, use of voice etc. Rider does not re-ride the movement. The Error is scored as above.

## 18. Dressage

Dressage Rule Reference USEF DR121-2

### 18.1. Required Equipment

18.1.1. **Bits** - The only bit permitted is the Snaffle Bit.

All snaffle bits must be smooth with a solid surface

18.1.1.1. Bit checks may be done, at the discretion of the judge, after the completion of the test. These may be done by a qualified volunteer or a judge.

18.1.2. **Cavesson**

Dropped, Flash, Crescent, Crossed and regular nosebands are the useable options. Padded nosebands are permitted

18.1.3. **Saddles**

Dressage, forward or all purpose saddle

### 18.2. Optional Equipment

1. Spurs of an English type

Spurs-made of metal, shank must be curved (pointing down) or straight pointing directly back from the center of spur. If rowels are used, they must be free to rotate

2. Crops, bats, or whips may be no longer than 44" for dressage including lash

3. Gloves

4. English breast plate

5. Braiding of mane or mane and tail in hunt style

6. ½ Chaps

### 18.3. Prohibited Equipment

1. Draw reins

2. Non-English type spurs

3. Western, Sidesaddles, or cutback (saddle seat type) saddles

4. Bit converters

5. Gag Bits

6. Ribbon, Glitter, & Sparkle

Exception: Residual from Working Pairs when scheduling does not allow its removal

7. Any bit with a twist in the metal

8. Any bit with a curb chain or strap, i.e. Kimberwicke

9. Martingales

10. Bit guards

11. Protective boots

12. Leg wraps

13. Bandages

14. Side Pulls

15.7.7. At the sixty (60) second mark, the team will be notified:

15.7.7.1. May be done by the announcer; **“thirty (30) seconds.”**

15.7.7.2. May be done by an automated timer and horn.

15.7.8. Any three (3) cows may be on the pen side of the time line at any time, but the fourth (4) cow results in **too many cattle** and a **no time** will be awarded.

15.7.9. Teams may opt to pen one (1), two (2), or three (3) head of cattle.

15.7.10. The team will signal their intention to call time by one or more of the members riding their equine’s shoulder to the pen gate and raising their arm(s).

15.7.10.1. At this point all other cattle on the pen side of the **time line** are considered “dirty”.

15.7.10.2. At this point the **Pen Judge** will determine if time can be called.

15.7.10.3. If the team is in the correct position and there are no “dirty” cattle,

15.7.10.3.1. the Pen Judge will drop his/her flag,

15.7.10.3.2. the timers will stop their watches/timer

15.7.10.3.3. the announcer will call the team’s time and number of cattle penned.

15.7.10.4. If there are **“dirty” cattle**,

15.7.10.4.1. the **Pen Judge will point his/her flag at the Line Judge** who waits for all of the “dirty” cattle to cross to the herd side of the *time line* and then drops his/her flag.

15.7.10.4.2. The timers will then stop their watches/timer, and

15.7.10.4.3. The announcer will call the team’s time and number of cattle penned.

15.7.10.5. If at any time, after the team has requested that time be called and before the Line Judge drops his/her flag, any part of a cow in the pen breaks the plane of the gate a **“no time”** will be awarded.

## 15.8. Re-Rides

- 15.8.1. In the event a team is given a number that has already been used on a herd during that go, a re-ride must be given immediately upon discovery, using the correct number within the same herd.
- 15.8.2. In case of other official or mechanical error, a re-ride shall be given at the end of that herd using the same numbered cattle.
- 15.8.3. As each new team begins a run, there should be a full herd in the arena. In the event that a team draws a number where more or less than three identical numbers are in the arena (at the time of their run), that team must have a re-ride at the end of the same herd, on their same numbered cattle.
  - 15.8.3.1. Times for all other teams with such a mis-numbered herd will remain the same.
- 15.8.4. If an animal leaves the arena, the team can be given one of the following
  - 15.8.4.1. a “no-time” for unnecessary roughness;
  - 15.8.4.2. a qualifying time on their remaining cattle;
  - 15.8.4.3. a re-ride (at the end of the herd that the error occurred, using the same number), depending on the judge’s decision.
- 15.8.5. If more than one re-ride is given in any go-round, re-rides will be given in order of occurrence at the end of the same herd in which the error(s) occurred.
- 15.8.6. Once the team is **committed to the cattle**, no re-ride will be given, except in extremely unusual circumstances, because the “Luck of the draw” will apply.
  - 15.8.6.1. “Committed to the cattle” means that the team has crossed the foul line, the flag has been dropped to the start time on the run, and their cattle number has been called.
- 15.8.7. If the judge rules that a team is entitled to a re-ride, they will be allowed to ride at the end of the herd where the error occurred, and they will work the same cattle number.
  - 15.8.7.1. Teams receiving a re-ride will start their time at zero.
- 15.8.8. If a team observes an unfit, or injured, animal before committing to the cattle, the team must notify the Line Judge.

## 17.4. Headers

- 17.4.1. Headers are required **any time the equine is hitched to the driving vehicle except while the competitor is working his/her pattern**
  - 17.4.2. Must be a registered volunteer or athlete
  - 17.4.3. Athletes Must be in a team uniform
  - 17.4.4. Boots are required for all headers
- 17.5. A Safety Inspection of Equipment, by the Judge, will be performed prior to event.  
Equipment checks are part of the score. Grooming and clean gear will be noted and will be considered in the Overall Reinsmanship scoring.
- ## 17.6. Gaits
- 17.6.1. **Walk:** A free, flat-footed, regular and unconstrained walk of moderate extension is required. The equine should walk energetically, but calmly, with an even and determined pace.
  - 17.6.2. **Slow Trot/Jog:** The equine should maintain impulsion while showing submission to the bit.
  - 17.6.3. **Working Trot:** This is a pace between the strong and slow trot. The equine should go forward freely and straight; on a taut, but light rein.
  - 17.6.4. **Strong or Extended Trot:** This is a clear, but not excessive, increase in pace and lengthening of stride while remaining well balanced. Light contact to be maintained. Excessive speed will be penalized.

## 17. Driving

### Driving Reference OHA, USEF Chapter "DP"

#### 17.1. Required Equipment:

1. Blinders
2. On heavier vehicle, Thimbles or Breeching is required
3. Over Checks or Side Checks
4. Whip - (tip of the whip or lash must be long enough to reach the shoulder of the equine) must be held and used correctly

#### 17.2. Optional Equipment:

1. Aprons
2. Knee rugs
3. Gloves
4. Snaffle, Liverpool or Buxton, Full Cheek and Half Cheeks
5. Breeching (Heavier vehicles must have breeching)
6. Running Martingales *with* Rein Stops (Rubber or leather stops slipped onto the rein between the bit and the ring of the martingale).

#### 17.3. Prohibited Equipment:

1. Twisted or wire bits of any type
2. Boots or wraps of any type
3. Spurs
4. Gag bits

## 15.9. Hazing

15.9.1. Waving hands, kicking at or hitting cattle with: ropes, bats, reins, or any other equipment as a means to move the cattle, may result in a warning, or a **no time** at the judge's discretion.

15.9.1.1. Repeated or extreme instances of this conduct may result in disqualification or elimination of the team.

15.10. **Roughing.** A team may be given a warning or a **no time** for any action the judge deems to be unnecessary roughness to the cattle, or the equine, or unsportsmanlike conduct.

15.11. Any "**spotting**" of cattle by anyone other than the team in the arena, shall result in the team being awarded a **no time**.

15.11.1. **Spotting shall be defined as** providing information to the team as to the location of the called number for that team for the purpose of cutting the cattle from the herd.

## CFL Enterprises, Inc.

Laughlin Arena  
Boarding Facilities

Full Care • Self Care



Cathy Phillips

18701 NE Laughlin Road, Yamhill

Office: 503-882-3551 • Cell: 503-434-2902

Animal Bedding  
Pellets

Made from 100%  
wood by-products

By the Ton • By the Bag

## Did you know?

You can support OHSET and get exposure for your business or organization by sponsoring an ad in the 2010 Rule Book.

- *Your ad will appear in 1800 Rule Books, used extensively by OHSET athletes and coaches.*
- *Ad proceeds help offset direct costs to athletes.*

For information about placing an ad, please contact Debi Ferrer (541) 993-2016 or [debi@gorge.net](mailto:debi@gorge.net)

15.11.2. **“Spotting” does NOT refer to** other comments (e.g. warning that the herd is moving toward the foul line, warning that selected cattle are returning to the herd, etc.).

15.12. If an **athlete becomes grounded** during their go, they shall have the opportunity to remount and continue only if their equine has remained ground tied. (Equine has not moved more than one equine length from the athlete. Otherwise, a **no time** shall be awarded for that go.)

15.12.1. Any attempt by a grounded athlete to pen or move cattle shall result in a no time being awarded for that go.

15.13. **Placing** will be determined by the number of successful goes penned, followed by the most cattle penned, and finally, the least amount of time.

pool.” (Listing all other competing athletes for the school as alternates is OK).

16.18.1.1 The alternate pool must be named before the first meet.

16.18.2 In Drill Teams (Working Fours and Short Program), there will be unlimited potential use of alternate pool.

16.18.2.1 A school may pull 1,2,3,4 or more riders out of the “drill alternate pool” during the season as needed.

**16.18.2.2** In Drill, once an alternate is pulled from the “drill alternate pool” (i.e., used in a competition), that alternate may ride only on that specific drill team, and no other drill team (in competition) for the season.

16.18.2.3 When pulling in an alternate from the Drill Alternate Pool, that school’s advisor/coach **MUST** notify the meet office, in writing, **BEFORE** that Drill Team competes

**EXAMPLE #1:** 12 competing athletes in a school, and the school only fields one drill team - a short program. Names 6 primary riders to the drill team, and can name the remainder of the school’s competing athletes (6) to their Drill Alternate Pool. Any combination of riders from the original named 6 or from the original named Drill Alternate Pool may ride in competition at any of this season’s meets. Again, when a rider is pulled from their Drill Alternate Pool, the school’s advisor/coach **MUST** he meet office, in writing, **BEFORE** that Drill Team competes at that meet.

**EXAMPLE #2:** 16 competing athletes in a school, and the school fields 2 drill teams, one short program and one working 4s. The school names 4 primary riders to the working 4s team and 6 primary riders to the short program team. That leaves 6 riders left that can be named to the Drill Alternate Pool. When a member of the alternate pool is pulled and competes for one of the drill teams, they are then a part of that team, for the remainder of the season, are no longer in the alternate pool, and may not compete with the other drill team. Their Drill Alternate Pool has now dropped to 5. Those five remaining members in the Drill Alternate Pool are eligible to compete for either drill team at any competition.

## Mountain Spirit Equine Massage

*Soft Tissue Injury Maintenance and Massage Therapy*



*Regular Massage Keeps  
Your Horse Happy and Healthy,  
and Improves Performance*

**Pattie O'Brien**  
Certified Equine Massage Therapist

541-536-7870 or 541-419-8916  
Sydney1951@msn.com

**16.16.5 Fall Due to Collision:**

Five points (-5) for each occurrence. Shall be deemed to be any physical contact between two or more equine, two or more athletes, or equine and athlete with a wall or gate, which results in a fall. If equine or athlete is unable to continue, a substitute equine and/or athlete will be allowed to fill the position. The position may remain empty. Only the Captain/Co-Captain can call time. Time will stop and start on Captain/Co-captain signal.

**16.16.6 Re Group:**

Five points (-5) for each occurrence. May be done when a team has lost its organization and or athletes must change position to be able to continue. Extenuating circumstances such as severe tack breakage, fall of equines and or athlete, or medical emergency which results in the team unable to continue, they may ask the senior judge for permission to leave the arena and return at the end of the draw. Time and deductions will remain official; time keeper will record time when performance is stopped by Captain/Co-captain and start time when Captain/Co-captain signals to commence the performance.

**16.16.7 Time (4 to 6 minutes):** Five point deduction (-5) for each occurrence under or over the allotted time

**16.16.7.1** Timing starts when the first athlete passes through the entry gate and/or cones marking entrance and stops when the last athlete crosses the exit gate and/or cones.

**16.16.7.2** An official timekeeper will enforce this rule. Only the Captain/Co-captain can call time. Time will stop and start on Captain/Co-captain signal.

**16.17 Disqualification**

There shall be no disqualification of any drill performance except for the use of prohibitive equipment, cruelty/abuse, unsportsmanlike conduct

**16.18 Alternate Guidelines**

**16.18.1** If a school intends to field only one drill team, they still must name the alternates that may possibly compete this season, “drill alternate

**16. DRILL TEAM:**

16.1. Working Fours - Teams with four riders

16.2. Short Program - Teams with 6 or more riders

**16.3. Required:**

16.3.1. Drill team may be ridden with English or Western Equipment.

16.3.1.1. Attire must conform to the discipline of equipment used.

16.3.1.2. Athletes from a school participating in a team event must be of the same discipline including the same color shirt for uniformity.

16.3.2. Equipment should be clean, in good working order and safe.

16.3.3. Bridles must be worn

**16.4. Optional:**

1. Hackamore

2. Standing Martingales and tie downs (attached to/or under a breast collar)

3. Running Martingales with Rein Stops. Rein Stops (rubber or leather stops slipped onto the rein between the bit and the ring of the martingale) are required on Running Martingales.

4. Protective boot, leg wraps and bandages

5. ½ Chaps & Leggings

6. Nose bands

7. Ribbons, glitter and sparkles on equine

8. Side Pulls

10. Gag Bits

**16.5. Prohibited:**

1. Wire chin straps, regardless of how padded or covered

2. Decoration/costuming of athlete uniform.

3. Any chin strap narrower than ½ inch

4. Draw reins

5. Jerk lines

6. Tack collars

7. Chaps & chinks

8. Sunglasses

9. Skirts (sidesaddle)

10. Bit Converters, A device used on pelham bits to change them from two-rein bits to one-rein bits. It is a leather strap that attaches from the snaffle ring to the curb ring, onto which the rein is then attached to the loop made between the two rings

## Images Properties Proudly Presents:

Three beautiful Apartment Complexes for your renting needs.....  
Pets are welcome. Bring this ad in and receive a large discount on move in costs.

### **Images Columbia** 13424 NE Sandy Blvd, Portland 503-830-9920

Fabulously large 2 & 3 bedroom units with washer/dryer hookups, balconies or private yards, Some with views of Mt Hood. Bus route at front of property.



### **Images Highland** 4725 W. Powell Blvd., Gresham 503-830-9249

2 bedroom with washer/dryer hookups as well as stackable washer/dryers. Well maintained, well located property, also with balconies and fenced yards. Walk to a variety of shopping centers as well as bus stop at entrance.

### **Images Springcreek** 2406 SE Harrison St, Milwaukie 503-860-5860

Gorgeous pool, plus 2 saunas await you here as well as extravagantly large 1, 2, and 3 bedrooms. Walk to farmers market in the spring. Wonderful small town feeling with many units delightfully backed to a surreal creek and country setting.



\*Some restrictions apply and discounts may change at anytime.

girth cover, leg bands, Flag/pennant and poles should be uniform.

#### 16.15.5 **Horsemanship**

Good equitation/horsemanship with balanced seat shall be emphasized.

Two hands are permitted on the reins for English or Western, one hand is preferred, but not required. Ridden correctly one hand should score higher than two hands. There should be light contact without undue restraint on the reins; proper use of hands and legs, correct leads shall be evaluated. Degree of difficulty is evaluated to determine quality of horsemanship.

#### 16.16 **Explanation of Point Value Deductions**

##### 16.16.1 **Broken or Dropped Equipment, Tack or Uniforms**

Two points (-2) for each occurrence. Shall include helmets, leg bands, pennants, flags, tail bows or anything that has fallen to the ground or broken in such a manner to necessitate stopping to repair it. The Captain/Co-Captain can call time. Time will stop and start on Captain/Co-Captain's signal.

##### 16.16.2 **Collision, No Fall of Equine or Rider**

Two points (-2) for each occurrence. Shall be deemed to be any physical contact between two or more equine, two or more athletes, or equine and athlete with a wall or gate which does not result in a fall. (Only the Captain/Co-Captain can call time. Time will stop and start on Captain/Co-Captain signal).

##### 16.16.3 **Excessive/Uncontrolled Speed.**

Three points (-3) for each occurrence. Riders will be considered to have excessive/uncontrolled speed if athlete loses control or a severe loss of precision due to speed

##### 16.16.4 **Fall of Equine and/or Athlete, No collision**

Three points (-3) for each occurrence

A team will be able to halt, regroup and restart as soon as equine and athlete are in position. Same rules for restart as fall due to collision. If a flag athlete falls only the fall of equine and or athlete will be deducted, not the dropped flag. (Only the Captain/Co-Captain can call time. Time will stop and start on Captain/Co-Captain signal)

definition of maneuvers. Continuity, or how one maneuver leads to another. Variety of maneuvers. The patterns should not be all circles or all lines. A team moving from one maneuver to another without repeating should receive credit for variety.

#### 16.15.2 **Spectacularity/Crowd Appeal**

Refers to the execution of maneuvers. Teams should be alert, wide-awake and at attention at all times. Speed shall be noted because it is more difficult to do a maneuver well when it is done at a faster speed. Precision shall not be sacrificed for speed. Speed is to be used only as an added point for spectacularity.

##### 16.15.2.1 **Crowd appeal**

Placement of maneuvers in arena for maximum audience enjoyment. Music that is suitable for the drill in both theme and tempo; flag presentation shall include manner in which the flags are carried. The shafts shall be perpendicular with forearm parallel to the ground. Elbows should be fixed at a right angle; the emblem should be pointed forward. Flags should be kept free and not allowed to wind around the pole

#### 16.15.3 **General Impression**

##### 16.15.3.1 **Presentation/Pattern Design:**

Drill pattern shall flow from maneuver to maneuver and should be easy to follow. The drill explanation and pattern forms should be drawn in such a manner that anyone without knowledge of drill could understand and see how the drill flows. The pattern should be drawn with clean presentation and writing. The forms turned in for the judges must match the drill being performed by the team. If the drill presentation is not complete, legible and clear, judges may mark down for this category.

##### 16.15.4 **Uniformity equine/equipment**

Shall be of like style. Saddles, bits, bridles and use of tie downs are not required to be identical within a team. Breast collar, saddle pad covers,

#### 16.6 **Judges:**

16.6.1 Three (3) Judges are recommended, but not required at District level.

16.6.2 Four (4) Judges will be used at State.

#### 16.7 **General Drill Rules**

16.7.1 Position in the **show schedule** will be determined by the show chairman or committee.

16.7.2 All equines will be **serviceably sound** and in good condition. Any equines showing signs of lameness or unsoundness will not be allowed to compete.

16.7.3 Drill team coaches or other athletes will not be allowed in the arena while their team is competing. Coaching or encouraging from outside the arena is permissible.

16.7.4 During drill competition only equines involved in the performance will be allowed in the arena.

16.7.5 During assigned practice periods only the equine in the drill activity will be allowed in the arena.

16.7.6 During practice only coaching staff will be allowed in the arena on foot. All athletes must be mounted.

16.7.7 There is a **time limit** of 4 to 6 minutes per team to perform a drill

16.7.7.1 Times for length of each drill performance will be recorded on the official scorecard.

16.7.7.2 Time scores are to be taken by official timers and reported to the judges.

16.7.7.3 Time starts when the first rider enters the arena and stops when the last rider leaves the arena.

#### 16.8 **American Flag Protocol**

16.8.1 Standard per Public Law 94.344 use of the United States Flag:

1. The Flag should never be carried flat or horizontal, but always aloft and free.

2. The U.S Flag should not be dipped to any person or thing.

3. Regimental colors, state, city, organizational or other flags are dipped as a mark of honor.

4. Do not let the Flag of the United States touch anything beneath it, such as the ground, floor, water or merchandise.

5. The United States flag should always be the first in, and the first out, of the arena

6. The United States Flag should always be carried in front of all other flags.

7. The United States Flag should always be carried on the right side of a company front.

#### 16.9 Musical Accompaniment

16.9.1 Teams may ride to music for the purpose of crowd appeal.

16.9.2 Should the music stop or there be interruption or malfunctions, the drill shall continue without music.

#### 16.10 Teams

16.10.1 Schools are to be allowed to field as many drill teams as they would like.

16.10.1.1 Only the highest place team for each high school in a team event will count toward meet team points from either short program or working fours, but not both.

16.10.1.2 Before a large team (16 or more) can field a second Working Fours team, they must do a Short Program drill.

16.10.2 Athletes can only compete in one (1) drill for any team at each competition.

16.10.3 Rules for listing team members and alternates will follow guideline as in all other team events.

16.10.4 Teams cannot switch from one program to the other after they have made a commitment or they shall forfeit all accumulated points.

#### 16.11 Presentation

16.11.1 Each Drill Team will be required to submit up to five (5) copies of the Explanation Sheet and Drill Pattern Form listing of all maneuvers in order of appearance in their drill.

16.11.1.1 These documents will be submitted by the designated District or State Championship committee to the Drill Judges **two (2) weeks prior to district and Championship meets.**

16.11.1.2 Failure to provide proper documentation in a timely fashion and in a legible form will result in a loss of presentation points

16.11.1.2.1 Point loss may be up to 10 points per judge, at the discretion of the judge.

#### 16.15 Drill Team Judging Guidelines

##### 16.15.1 Execution of Drill

###### 16.15.1.1.1 Alignment/Accuracy:

Vertical and horizontal alignment in maneuvers of a team. Lines should always be straight whether in squads, columns, company front, etc.

###### 16.15.1.1.2 Spacing:

Maintaining a uniform distance between all equines throughout an entire maneuver. Distance may be varied as long as it is equal.

###### 16.15.1.1.3 Timing/ Coordination:

How athletes work together in the performance of their maneuvers. There are no missed holes, collisions, etc. A team should move as a unit and be smooth in its maneuvers. This includes the ability of the team to foresee the necessity to adjust its speed to the maneuver without breaking gait. Both spacing and gait are to be maintained. The team will be penalized for loss of gait unless change of pace is obviously a part of the maneuver

###### 16.15.1.1.4 Equine Manners and Performance

Equines are expected to be responsive, quiet and obedient. Faults include broken gaits (jogging during the loping phase or loping during the trotting phase), disobedient (blowup, fit), striking or biting. Pinning ears or active tail should **not** be judged for equine manners. Manners are ways of going and suitability as a drill equine. Equines should be well behaved. They should not jump or shy and should work freely and easily at all times. They should stand quietly and straight in line and not move until the signal is given.

###### 16.15.1.1.5 Drill Design\

###### Originality/Uniqueness

Patterns or methods of presentation, attractiveness of pattern, symmetry and

- 16.14.4 There are six (6) Permanent Required and six (6) Drawn Required maneuvers in OHSET drill.
- 16.14.5 Each of the twelve (12) maneuvers must be exhibited and can not be combined or substituted with any other maneuver.
- 16.14.6 **Permanent Required Maneuvers**
- 16.14.6.1 A Change of Pace**  
A definite change of pace from lope/trot-walk or any combination. Pace should remain for the length of arena, across the arena or a complete revolution in circles or pivots. All team members should perform the change all at the same time, or all at the same location in the arena
- 16.14.6.2 Maneuver by Pairs**  
Any maneuver ridden in pairs
- 16.14.6.3 **Maneuver by Fours**  
Any maneuver ridden in fours
- 16.14.6.4 Single File Cross**  
Two single file lines, crossing ahead of or behind each on-coming rider. Riders may approach from same end or opposite ends of the arena. Variations shall include leaving the long sides or short ends of the arena. Spacing may vary.
- 16.14.6.5 Single Line Abreast**  
A single line abreast MOVES whether moving forward or in circular motion.
- 16.14.6.6 **Circle**  
Riders in a close plane, equidistant from a fixed center point.
- 16.14.7 **Drawn Maneuvers**
- 16.14.7.1 These maneuvers will be drawn each year and will be listed each year on the Drill Explanation Sheet.
- 16.14.7.2 Maneuvers for Short Program and Working 4's may vary. If this happens a Drill Explanation Sheet will be presented for each program.

# Eve's RiderWear

AN EQUESTRIAN BOUTIQUE

## Shopping List

- Bling Belts
- Jewelry that sparkles
- Fun Horsey Gifts
- Cool Jeans
- FABULOUS Handbags
- Show Shirts and stuff!

432 McClaine Street, Silverton Oregon

(503) 873-0480

[www.EvesRiderWear.com](http://www.EvesRiderWear.com)

See you at the NEXT OHSET Meet!

- 16.12 **Short Program**
- 16.12.1 Six (6) Primary athletes must participate in the execution of all permanent required maneuvers and all drawn maneuvers.
- 16.12.2 Extenuating circumstances may allow teams competing in the Short Program to ride with less than six (6) athletes in District/State Competitions.
- 16.12.2.1 It may be considered an extenuating circumstance if an equine or athlete is injured or ill and there is no replacement.
- 16.12.2.2 The Stewardship Committee shall determine if a situation falls under this rule, and must grant permission before the team rides.

- 16.13 **Working Fours**
- 16.13.1 Shall consist of no less than four athletes.
- 16.13.2 Four athletes must participate in the execution of all permanent required maneuvers and all drawn maneuvers.
- 16.13.2.1 Extenuating circumstances may allow teams competing in the Working Fours to ride with less than four (4) athletes in District/State Competitions.
- 16.13.2.2 It may be considered an extenuating circumstance if an equine or athlete is injured or ill and there is no replacement.
- 16.13.2.3 The Stewardship Committee shall determine if a situation falls under this rule, and must grant permission before the team rides.

- 16.14 **Maneuvers**
- 16.14.1 A complete list of drill maneuvers and drill design sheets are available on the OHSET web site [www.ohset.com](http://www.ohset.com)
- 16.14.2 OHSET reserves the right to create and/or select drawn maneuvers whenever deemed necessary or desirable by the judges committee. Drawn Maneuvers will be released to the Districts in the first week of October.
- 16.14.3 Teams may design their Drill when maneuvers are released.
- 16.14.3.1 Teams may **not** practice drill with or without an equine until December 1.



**Jeff Pelton, DVM**

drpelton@fourhoooves.net www.fourhoooves.net

*A full service large animal veterinary clinic  
providing medicine, diagnostics,  
digital x-rays, dentistry, and more.*

34817 Matthews Rd.  
Eugene, OR 97405

Ph: 541-335-1379  
Fax: 541-741-0245

**READ YOUR RULE BOOK!**



**Best Wishes from 2008 Graduates  
Bailey, Sydney, Sarah and Samantha  
The Dalles Wahtonka High School**